

REV	DESCRIPTION	DATE	ENGR	DFT
A	INITIAL RELEASE	02/15/94	HG	
B	ITEM NO.5 WAS #206002340 AND ITEM NO.6 WAS #206002062	7/7/94	HG	
C	CI WAS 506001001, C2 & C3 ADDED	02/08/02	PHD	
D	ITEM #17 WAS P/N 206001028	10/03/02	KHN	
E	RUBBER BUMPER - WAS P/N 206 004 004	7/8/03	KHN	

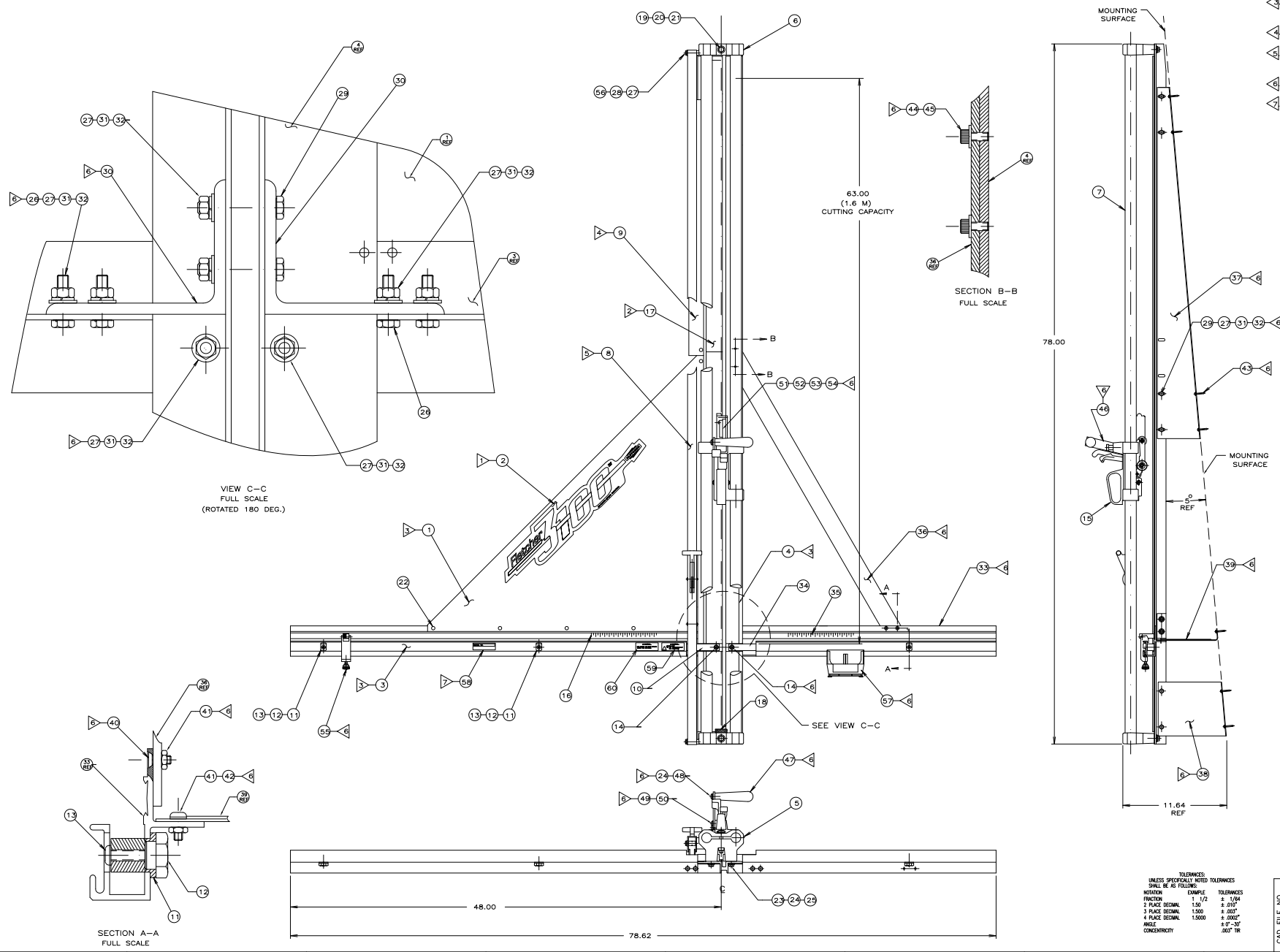

- NOTES
- SEE ASSEMBLY DWG # 206001057 FOR THE LOCATION OF LOGO PLACEMENT.
 - APPLY TAPE ADHESIVE # 022-004-711 ON VERTICAL CHANNEL (APPLYING SURFACE MUST BE CLEAN & DRY) POSITION AND ASSEMBLE WEAR PLATES WITHIN .005-.015 FROM GROOVE'S EDGE. WEAR PLATES MUST BE FIRMLY ADHERED TO EXTRUSION AFTER ASSEMBLY. SQUARE UP VERTICAL AND HORIZONTAL CHANNELS AGAINST FACE PLATE PRIOR TO DRILL .158 DIA. THRU (10X) FOR RIVETTING.
 - POSITION AND RIVET FILLER AGAINST FACE PLATE AND VERTICAL CHANNEL AS SHOWN.
 - ADJUST MAT CLAMP ASSEMBLY TO LOCK FLAT AGAINST FACE PLATE PRIOR TO FASTEN CLAMP ASSEMBLY INTO THE MACHINE.
 - DO NOT ASSEMBLE THESE ITEMS. TO BE INSTALLED BY CUSTOMER.
 - CENTRALLY LOCATE AND APPLY MODEL # LABEL AS SHOWN. (APPLYING SURFACE MUST BE CLEAN & DRY)

QTY	PART NO.	DESCRIPTION	ITEM
1	506010314	CAUTION LABEL (SHARP)	60
1	506010312	CAUTION LABEL	59
1	506999444	SERIAL & MODEL LABEL	58
1	406001048	PLASTIC BIN	57
1	406003048	HEX HEAD BOLT	56
1	206001052	MEASURING STOP ASSY.	55
1	206001042	HARD BOARD PILLAR POST	54
1	206001041	PLASTIC PILLAR POST	53
1	206001040	MAT BOARD PILLAR POST	52
1	206001039	GLASS PILLAR POST	51
2	406004129	LOCK WASHER	50
2	406001032	#10 BUTTON HD.CAP SC.	49
1	406001031	5/16 BUTTON HD.CAP SC.	48
1	406001030	HANDLE	47
1	206001029	HANDLE BRACKET	46
2	406004130	WASHER	45
2	406003059	#10 SOCKET HD.CAP SC.	44
13	406205000	HEX HEAD WOOD SCREW	43
4	406005117	#10 PAN HD.MACH SC.	42
6	406204000	#10 HEX NUT	41
2	406005116	#10 FLAT HD.MACH SC.	40
2	406004097	HORIZONTAL SUPPORT	39
1	406004095	LOWER MOUNTING BRACKET	38
1	406004175	UPPER MOUNTING BRACKET	37
1	206003017	BRACE	36
1	206001024	R. H. SUPPORT SCALE	35
1	206002014	R. H. SUPPORT SQ. BAR	34
1	206002002	R. H. SUPPORT EXT.	33
14	406196000	HEX NUT	32
14	407415300	LOCK WASHER	31
2	206004031	ANGLE BRACKET	30
8	406001015	HEX BOLT	29
1	406003042	SPRING SLEEVE	28
15	406712200	WASHER	27
4	406288000	HEX BOLT	26
4	406004119	WASHER	25
5	406004124	LOCK WASHER	24
4	406004120	HEX BOLT	23
13	406004139	RIVET	22
2	406004123	SQUARE NUT	21
2	406004121	WASHER	20
2	406004122	HEX BOLT	19
1	406004099	BUMPER	18
2	206001036	WEAR PLATE	17
1	206004054	HORIZONTAL SCALE	16
1	206001038	CUTTING HEAD ASSY.	15
2	406002012	SHOULDER SCREW	14
3	406002011	BUTTON HD. CAP SCREW	13
3	406003006	ECCENTRIC HEX	12
3	406003007	SPACER	11
1	206002013	SQUARING EDGE BAR	10
1	206003057	FILLER	9
1	206001046	CLAMP ASSEMBLY	8
2	206002017	TUBE	7
1	206001062	UPPER END BRACKET	6
1	206001060	LOWER END BRACKET	5
1	206001003	VERTICAL CHANNEL	4
1	206002001	HORIZONTAL CHANNEL	3
1	506001012	F 3100 LOGO	2
1	406004140	FACE PLATE	1

CAD FILE NO. 206001057-MSB
PROJECT NO. 101

UNLESS SPECIFICALLY NOTED TOLERANCES SHALL BE AS FOLLOWS:
 INCHES: FRACTION: 1/32 ± 1/64
 DECIMAL: 1.50 ± .002
 2 PLACE DECIMAL: 1.50 ± .003
 3 PLACE DECIMAL: 1.500 ± .002
 4 PLACE DECIMAL: 1.5000 ± .0002
 ANGLE: ± 0°-30'
 CONCENTRICITY: .005" TR

EXAMPLE: 1 1/2 ± 1/64
 1.50 ± .002
 1.50 ± .003
 1.500 ± .002
 1.5000 ± .0002
 ± 0°-30'
 .005" TR

DATE: 6/7/94
 DWG. NO.: D 1/5:1 206 001 058
 SCALE: 1:1
 DRAWING NUMBER: E
 REV. LEVEL: E

FLETCHER 3100 MACHINE ASSEMBLY

THE FLETCHER-TERRY COMPANY
 SPRING LANE, FARMINGTON, CONN.



F3000 / 3100s
(Continued)
F3100

FRAME

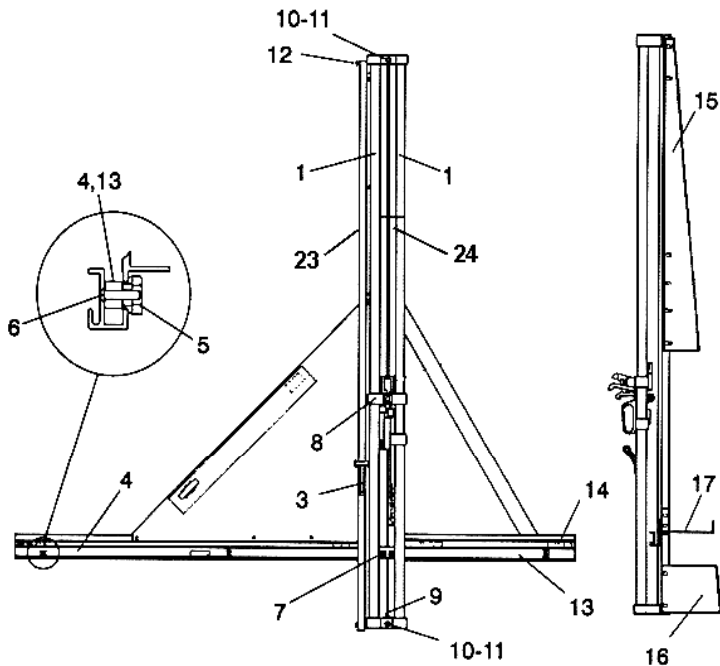

CUTTING HEAD

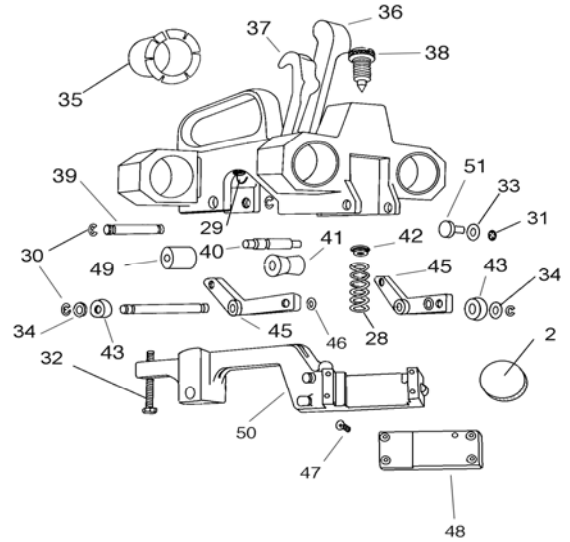

**WEB /
BOOK**

REF #	PART NO.	9-DIGIT	FOR WEB USE	DESCRIPTION	QTY.
1	12-200	206002017	Frame	Tubes - Vertical 63"	2
3	12-201	206001046	Frame	Clamp Assembly	1
8	12-202	206001038	Frame	Cutting Head Assembly	1
4	12-203	206002013	Frame	Left Squaring Edge Bar	1
13	12-204	206002014	Frame	Right Squaring Edge Bar	1
6	12-205	406002011	Frame	Button Head Cap Screw	3
7	12-206	406002012	Frame	Shoulder Screw	2
14	12-207	206001024	Frame	Scale - Right Square Edge	1
2	12-210	406001011	Cutting Head	Speed Screw	1
50	12-216	206001047	Cutting Head	Rocker Arm Assembly (Black)	1
36	12-217	206001051	Cutting Head	Clamp Lever Assembly (Black)	1
47	12-221	406004150	Cutting Head	Screw	4
48	12-222	206001014	Cutting Head	Cover Plate	1
49	12-223	406002024	Cutting Head	Nylon Sleeve	1
15	12-228	206004175	Frame	Upper Wall Mounting Bracket	1
n/a	12-229	206001044	Frame	Clamp Lever Assembly	1
24	12-232	206001036	Frame	Wear Plate	1
51	12-234	406001010	Cutting Head	Wear Pad	2
41	24-082	406004082	Cutting Head	Roller (Inside)	1
43	24-083	406004083	Cutting Head	Roller (Outside)	2
44	24-084	406004084	Cutting Head	Roller Shaft	1
16	24-095	406004095	Frame	Lower Wall Mounting Bracket (60" Machine)	1
17	24-097	406004097	Frame	Horizontal Support (Left Side) (60" Machine)	2

F3000 / 3100s
(Continued)

WEB /
BOOK

REF #	PART NO.	9-DIGIT	FOR WEB USE	DESCRIPTION	QTY.
9	24-099	206004099	Frame	Rubber Bumper	1
29	24-101	406004101	Cutting Head	Breaker Spring	1
38	24-104	206004104	Cutting Head	Pressure Adjusting Screw	1
35	24-106	406004106	Cutting Head	Tube Bushing	3
32	24-113	406004113	Cutting Head	Rocker Arm Adjusting Screw	6
30	24-114	406004114	Cutting Head	Retaining Clip	6
34	24-115	406004115	Cutting Head	Roller Washer	2
33/46	24-116	406004116	Cutting Head	Pivot Shaft Washer	2
10	24-122	406004122	Frame	End Bracket Hex Head Bolt	2
42	24-136	406004136	Cutting Head	Plastic Bushing for Adjusting Screw	1
31	24-410	407410600	Cutting Head	Retaining Ring	2
5	36-012	406003006	Frame	Eccentric Hex Nut	3
11	36-017	406004123	Frame	Clamp Slide Nut/Washer	2
12	36-024	406003042	Frame	Mat Clamp Spacer	2
28	36-036	406003028	Cutting Head	Pressure Spring	1
39	36-038	406004087	Cutting Head	Shaft - Trigger & Lever	1
37	36-039	206001049	Cutting Head	Trigger (Black)	1
51	36-041	406003008	Cutting Head	Wear Pad	2
45	36-042	206001053	Cutting Head	Pivot Arm (Black)	2
40	36-043	406004085	Cutting Head	Pivot Arm Shaft	1
23	36-056	406002055	Frame	Rubber Strip/Clamp Pad	59"