



*Alfamachine*

A Fletcher Company

EN

# INSTRUCTIONS MANUAL



## **U300** *Semi-Auto/Pneumatic Underpinner*

Name	FRAME ASSEMBLING MACHINE
Function	ASSEMBLY OF FRAMES BY INSERTION OF METAL V-NAILS
Model / Type	U300 (previous version MINIGRAF 3)
Serial number	
Year of construction	
Manual Revision	01

**PLEASE RETAIN FOR FUTURE REFERENCE**



**Alfamacchine S.r.l.**  
Via Selva 23/25  
47122 Forlì - Italy

**CE DECLARATION OF CONFORMITY**  
**CE CONFORMITY DECLARATION**

Il Fabbricante / the Manufacturer  
con sede legale in / Address

**Alfamacchine S.r.l.**  
Via Selva, 23/25 47122 Forlì - Italy

**DICHIARA, / Hereby DECLARES,**

sotto la propria responsabilità,  
declares that the machine:

under its sole responsibility,  
that the machine:

Denominazione / Product Name : FRAME ASSEMBLING MACHINE

Funzione / Purpose : ASSEMBLY OF WOODEN AND SYNTHETIC MDF MOULDINGS USING METAL  
V-NAILS

Modello/ Model Name : **U300**

Tipo / Type : PNEUMATIC

Numero di Serie / Serial Number :

E' CONFORME ALLE DISPOSIZIONI PREVISTE DALLE DIRETTIVE:  
COMPLIES WITH THE FOLLOWING STANDARDS AND DIRECTIVES:

- 2006/42/CE, Direttiva Macchine / Machinery Directive

poiché rispetta tutti i requisiti essenziali di sicurezza e sanitari che le concernono.  
because it complies with all the relative essential safety requirements

Technical File drawn up by: ALFAMACCHINE S.R.L.  
Technical File drawn up by: ALFAMACCHINE S.R.L.

Forlì ,

\_\_\_\_\_  
Data / Issued Date :

\_\_\_\_\_  
Firma il Legale rappresentante / Signature of representative

# EN TRANSLATION OF THE ORIGINAL INSTRUCTIONS

## INDEX

<b>1. INTRODUCTION TO USE</b> .....	<b>2</b>
1.1. HOW TO CONSULT THIS MANUAL AND THE SYMBOLS ADOPTED .....	2
1.2. WARNING STICKERS - INDICATIONS (see figure) .....	2
1.3. TYPE OF USE AND CONTRAINDICATIONS.....	2
1.4. TECHNICAL FEATURES .....	6
1.5. PRODUCTS PROCESSED - HANDLED OR GENERATED .....	7
1.6. EMISSION OF AIRBORNE NOISE.....	8
1.7. RESIDUAL RISKS - GENERAL INFORMATION .....	8
1.8. RESIDUAL RISKS .....	8
1.9. DESCRIPTION OF SAFETY FUNCTIONS.....	9
1.10. DESCRIPTION OF THE MACHINE.....	11
1.11. MAIN MACHINE COMPONENTS .....	11
<b>2. INSTALLATION</b> .....	<b>16</b>
2.1. STORAGE.....	16
2.2. CHECKS ON RECEPTION.....	16
2.3. TRANSPORT, LIFTING AND HANDLING.....	17
2.4. LIFTING AND HANDLING .....	17
2.4. LIFTING AND HANDLING .....	17
2.5. REMOVING THE PACKAGING .....	18
<b>3. PRELIMINARY PREPARATION AND ADJUSTMENT PROCEDURES</b> .....	<b>20</b>
3.1. POSITIONING.....	20
3.2. LEVELLING THE MACHINE.....	20
3.3. ASSEMBLY OF SEPARATELY SHIPPED UNITS .....	21
<b>4. INITIAL START-UP AND USE OF THE MACHINE</b> .....	<b>25</b>
4.1. WORKSTATIONS AND OPERATORS' TASKS.....	26
4.3. CHECKS, ADJUSTMENTS AND START-UP .....	26
4.4. START-UP.....	27
4.5. WORKING CYCLE.....	38
4.5.1. CYCLE STOP .....	39
<b>5. MAINTENANCE, TROUBLESHOOTING, AND CLEANING</b> .....	<b>40</b>
5.1. MAINTENANCE TECHNICIAN REQUIREMENTS .....	40
5.2. WORK STATIONS AND MAINTENANCE TECHNICIAN DUTIES .....	40
5.3. MAINTENANCE PRESCRIPTIONS.....	40
5.4. GENERAL WARNINGS .....	41
5.5. ISOLATION FROM EXTERNAL ENERGY SOURCES.....	41
5.6. ROUTINE MAINTENANCE.....	41
5.7. TASKS THAT CAN BE PERFORMED BY THE OPERATOR .....	42
5.8. TASKS THAT CAN BE PERFORMED ONLY BY MAINTENANCE TECHNICIANS .....	43
5.9. CLEANING.....	46
<b>6. TROUBLESHOOTING AND RELEASE OF MOVING PARTS</b> .....	<b>50</b>
<b>7. REINSTALLATION AND REUSE</b> .....	<b>52</b>
<b>8. EXTINGUISHING MEDIA</b> .....	<b>52</b>
<b>9. SCRAPPING AND DISPOSAL</b> .....	<b>52</b>
9.1. SCRAPPING .....	52
9.2. DISPOSAL .....	53
<b>TABLE 0 - EXPLODED VIEW OF THE MACHINE</b> .....	<b>54</b>
<b>TABLE 20 - HEAD UNIT INSTALLATION</b> .....	<b>55</b>
<b>TABLE 21 - FENCE UNIT INSTALLATION</b> .....	<b>56</b>
<b>TABLE 22A - AFC BRAKE</b> .....	<b>57</b>
<b>TABLE 22B - ROD CLAMP</b> .....	<b>57</b>
<b>TABLE 23 - VERTICAL CLAMP UNIT</b> .....	<b>58</b>
<b>TABLE 24 - EC SAFEGUARD</b> .....	<b>59</b>

**! DANGER - WARNING**  
**BEFORE USING THE MACHINE PLEASE READ THIS MANUAL CAREFULLY SO THAT YOU BECOME FAMILIAR WITH THE MACHINE, ITS ENVISAGED USE AND ANY RISKS ASSOCIATED WITH IT.**

Keep the Use and Maintenance Manual in good condition: Remember, it is an integral part of the machine. Always refer to the manual to get best machine performance in maximum safety while performing the operations described therein. This manual must be kept in an easily accessible place, near the machine, at all times so that it can be consulted whenever necessary.

**! DANGER - WARNING**  
**USE THE MACHINE SOLELY AND EXCLUSIVELY FOR THE USES INDICATED AND IN ACCORDANCE WITH THE RECOMMENDATIONS PROVIDED IN THIS MANUAL. NEVER TAMPER WITH IT, FORCE IT OR USE IT IN ANY INAPPROPRIATE MANNER.**

## 1. INTRODUCTION TO USE

### 1.1. HOW TO CONSULT THIS MANUAL AND THE SYMBOLS ADOPTED

Please pay particular attention to the words "DANGER – WARNING", "DANGER – CAUTION" and "NOTE" as used in this manual. To draw the user's attention to certain information and provide warning messages, the operations described in this manual are accompanied by symbols and notes to highlight the presence of any hazards and indicate the safe use of the equipment. These symbols and notes belong to various categories, as indicated below:

**! DANGER – WARNING: IMPORTANT INFORMATION CONCERNING GENERAL SAFETY.**

**!** **DANGER-CAUTION: highlights situations where careful and sensible actions are essential.**

**M** **NOTES: information of a technical nature.**

### 1.2. WARNING STICKERS - INDICATIONS (see figure)

Sticker	Description
	Wear protective goggles.
	Wear protective gloves.
	Wear safety footwear
	Wear ear defenders.
	Risk of impact against obstacles: affixed on the corners of the guards.

### 1.3. TYPE OF USE AND CONTRAINDICATIONS.

**ATTENZIONE !**  
**PER LA VS. SICUREZZA**  
 DISINSERIRE L'EROGAZIONE DELL'ARIA PRIMA DI CAMBIARE LA TESTINA PER GRAFFIE O ESeguire LAVORI DI MANUTENZIONE SULLA MACCHINA

Safety warning on machine use

**ATTENZIONE**  
**TENERE LONTANO LE DITA**

ALFAMACCHINE S.p.A.  
 Via Sesto 23/25  
 41019 Foss (FC)

**CE**

EC dataplate

DENOMINAZIONE: \_\_\_\_\_  
 NUMERO DI SERIE: \_\_\_\_\_  
 MODELLO: \_\_\_\_\_  
 TIPO: \_\_\_\_\_  
 PESO: \_\_\_\_\_ kg  
 PRES LAVORO: \_\_\_\_\_ kg

## PERMITTED USE

The machine described herein is designed to be run by 1 operator suitably trained and instructed with regard to residual risks. The operator must have the same skills, in terms of safety, as the maintenance technicians and adequate professional competence.

During its PERMITTED AND REASONABLY PREDICTABLE USE, the machine may be used exclusively:

- to work with wooden mouldings of various hardness, with multiple surface finishes, for the purpose of making frames for pictures, mirrors, display cases, cupboard doors etc.) in accordance with the characteristics described in the heading "Products Processed - Handled or Generated". Use of the machine to perform processes other than those described in this manual is to be considered improper and therefore strictly prohibited.
- with the products (and materials) described and having the dimensions specified in the heading "TECHNICAL CHARACTERISTICS".

It is also compulsory:

- for the machine to be used by one operator only who has received adequate training/information concerning machine operations, performance and any hazards associated with its use.
- to ensure no exposed persons are present in the machine's operating area before proceeding with any operations whatsoever.
- to check the perfect condition of all the safety devices before starting to work with the machine.
- to ensure, when the machine is placed on the factory floor where it is to be used, that it is installed on a level, smooth and perfectly horizontal surface. The floor must have an adequate load bearing capacity to support the weight of the machine.
- to check, prior to starting work with the machine, the conditions of ambient lighting and ensure there are no areas of shadow, glare, or potentially hazardous strobe effects.
- to disconnect, prior to starting any work on the machine, the main compressed air supplies, to safely discharge any residual energy in the machine circuits, and wait for all parts at high temperatures to cool down adequately.

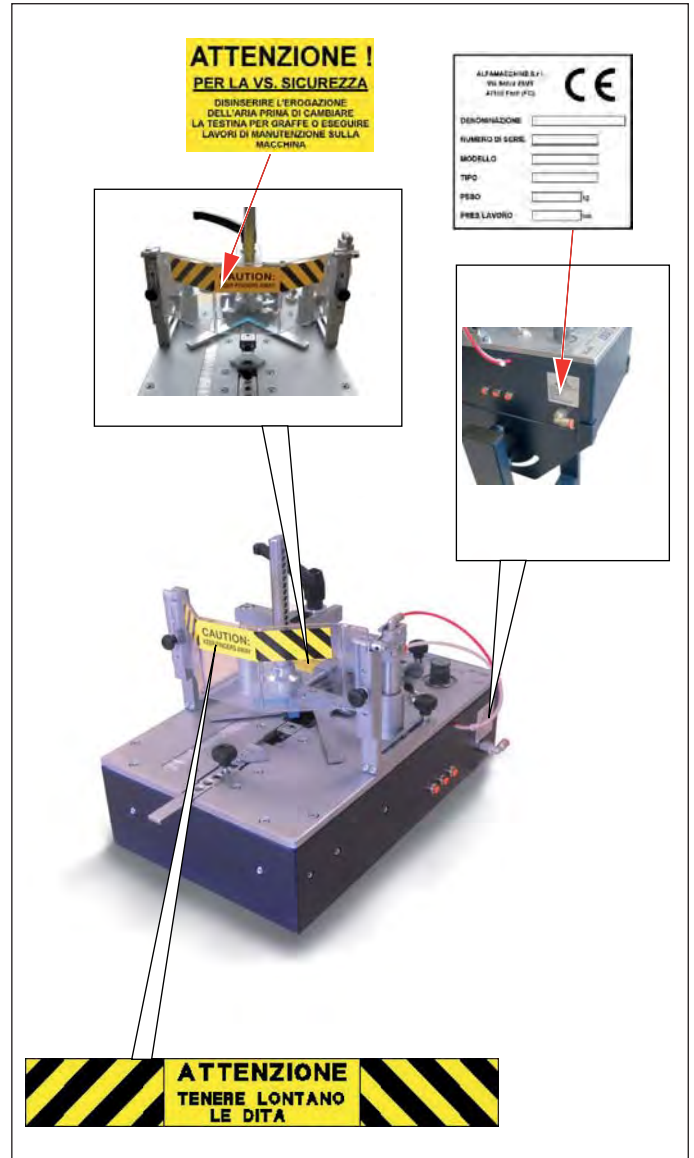

## UNINTENDED USE



### DANGER - WARNING

**THE MACHINE MUST NOT BE USED IN A PROHIBITED MANNER. SPECIFICALLY:**

- it cannot be operated with parameters different to those shown in the "TECHNICAL CHARACTERISTICS" table or with products and/or materials with different characteristics to those previously described in the heading "TECHNICAL CHARACTERISTICS".
- all uses of the machine other than those described in this manual are construed as improper and as such the manufacturer declines all liability.
- the user is responsible for any damage resulting from failure to observe the operating conditions agreed at the time of technical specification and order confirmation.

## **FORBIDDEN USE**

### **DANGER - WARNING** **FURTHERMORE IT IS PROHIBITED TO USE THE MACHINE IN AN INCORRECT MANNER, IN PARTICULAR:**

- never leave the loaded machine unattended,
- never use flammable, corrosive or toxic substances to clean the machine,
- never allow unauthorized personnel to use the machine,
- never smoke or use open flame equipment or handle incandescent material, unless adequate safety measures have been adopted,
- never activate or adjust the control and locking devices, such as knobs or similar devices, during machine operation or when not authorized to do so,
- never hang objects or weights on the machine,
- never use the machine with the safety guards open, incorrectly fastened, or removed,
- never use the machine with the safety microswitches and interlocking safety devices inhibited and, in general, with any safety and/or protective device (mechanical) deactivated and/or non-functional,
- never partially or totally by-pass, remove, modify or in any way render ineffective the guards, safety microswitches and warning signs,
- use of the machine is forbidden when the user has not adopted all the necessary measures to eliminate the residual risks as indicated in this instruction manual,
- never use the machine for operations other than those explicitly indicated in this instruction manual,
- never use the machine in environments for which it has not been designed unless all necessary safety measures have been adopted beforehand,
- the machine must not be used by untrained personnel
- foodstuffs must not be brought into contact with the machine,
- it is prohibited to activate the control devices for machine movements without first checking and ascertaining the absence of persons in the danger areas subject to machine movements,
- it is prohibited to enter the operating / danger zone of the machine during control of the machine's moving parts,
- it is prohibited to enter the machine working area with any part of the body, hands and arms included, before hazardous moving elements have come to a complete standstill.
- it is prohibited for the machine operator and maintenance technician to enter the danger zones to perform cleaning, lubrication, maintenance operations etc. without having first set the power cut-off switches to "ZERO" and padlocked them in this position,
- the machine must not be used in critical conditions of stability, i.e.:
  - when placed on a support surface which is not perfectly horizontal and smooth, or does not have an inadequate load capacity as indicated in this manual,
    - outdoors or worksites with open windows and doors,
- the following are strictly prohibited:
  - processing of materials and products that are not expressly indicated in the present manual,
  - processing of metal materials made of aluminium, lightweight alloys, and steel and its alloys.

### **DANGER – CAUTION** ***The manufacturer cannot be held liable for any faults caused by unreasonable, improper and/or incorrect use of the machine.***

The user is anyway responsible for all damage deriving from failure to comply with the specified terms of use. For any further information always consult the manufacturer's engineering department.

The user is always responsible for providing suitable personal protective equipment to machine operators and for informing them on the permissible uses of the machine.

## **PERSONNEL AUTHORIZED TO USE THE MACHINE**

This machine has been designed and manufactured to be used by qualified personnel with adequate training, experience and skills in accordance with the characteristics described below:

### **Operators / Apprentices:**

- may be male or female
- must be aged 14 or over
- must have full use of both hands
- must have no physical or mental disabilities
- must know and fully understand the contents of the user manual.

## **PERMITTED AMBIENT CONDITIONS AND OPERATING LIMITS**



### **DANGER - WARNING**

**THIS MACHINE IS NOT SUITABLE FOR USE IN POTENTIALLY EXPLOSIVE ENVIRONMENTS.  
THEREFORE IT IS PROHIBITED TO INSTALL OR USE IT IN ANY SUCH ENVIRONMENT.**

## **SERVICE CONDITIONS**

<b>SERVICE CONDITION</b>	<b>USER LIMITS</b>
Installation type	Indoor
Floor conditions	Horizontal and smooth: irregularity and gradient tolerance within 2%
Supporting surface characteristics	Flooring in compliance with health and safety requirements in the workplace in accordance with all applicable legislation
Maximum ambient air temperature	+40°C / 104°F
Minimum ambient air temperature	5°C / 41 °F (with electrical equipment protection rating of at least IP54) 0°C / 32 °F (with electrical equipment protection rating lower than IP54)
Ambient working temperature	+5°C / 41°F < T < +45°C / 113°F
Transport and storage temperature	between -25°C / -13 °F and +55°C / 131°F (temperatures of up to +70°C/158°F are admissible for periods of less than 24 h)
Maximum altitude above sea level	1000m
Minimum required light intensity	600 lux
Relative humidity of 100% at +25°C/ 77°F (electrical equipment protection rating of at least IP54)	
Relative humidity shall not exceed 50% at +40°C / 104°F or 90% at +20°C / 68 °F (electrical equipment protection rating below IP54)	
Equipment for machine designed for indoor installations	
Machine <b>NOT</b> suitable for operation in contaminated atmospheres: for example, dusts, acids, corrosive gases, salt or similar contaminants.	
Machine <b>NOT</b> suitable for operating in potentially explosive atmospheres classified as zone 0, zone 1 or zone 2.	
Machine <b>NOT</b> suitable for operation in environments subject to the presence of ionizing and non-ionizing radiation: for example, microwaves, UV rays, laser, X-rays, and similar.	
Electrical equipment <b>NOT</b> suitable for installation on machines or for operation in places subject to vibration and impact: otherwise, install equipment well clear of source of vibration and impact and fit antivibration supports.	
Pollution class of electrical equipment equivalent to 3 (THREE)	
Installation environment equivalent to two (2)	
Can be utilised in residential, commercial, of light industrial zones thanks to compliance with standard EN 61000-6-1	
Intended for direct/exclusive service of industrial process machinery	

SERVICE CONDITION	USER LIMITS
Special and additional prescriptions, not envisaged, may be requested for machines intended for:	<ul style="list-style-type: none"> <li>• outdoor use;</li> <li>• handling potentially explosive materials;</li> <li>• use in potentially explosive and/or flammable atmospheres;</li> <li>• use involving specific risks in the processing of specific materials;</li> <li>• use in mines;</li> <li>• use in refrigeration plants;</li> <li>• use at high temperatures;</li> <li>• use in corrosive environments;</li> <li>• use in strong magnetic fields;</li> <li>• use in radioactive conditions;</li> <li>• use for loads the nature of which could lead to hazardous situations (for example, molten metal, acids/bases, particularly fragile loads, explosives),</li> <li>• use on ships and areas affected by earthquakes;</li> <li>• food-contact use;</li> <li>• use in public areas;</li> <li>• use in aircraft ground support.</li> </ul>

#### 1.4. TECHNICAL FEATURES

##### Machine characteristics

Work surface dimensions (W x L).....	300x485mm - 12"x19"
Machine length.....	485mm - 19"
Machine width .....	300mm - 12"
Minimum height of working bench from the floor.....	1020mm - 34" 1/4
Maximum height of working bench from the floor.....	1340mm - 53"
Maximum machine height.....	450mm - 18"
Machine weight.....	32kg - 70lbs
V-nail magazine capacity .....	220 pcs
Max. quantity of V-nails inserted per position .....	9pcs
V-Nail insertion positions.....	Multiple
Max. distance between V-nails .....	80mm - 3" 1/4

##### Compressed air supply

Maximum permitted inlet pressure.....	8bar
Operating pressure 2 - 8 bar (see the details provided in the heading "Rod clamp and mobile fence adjustment")	
Specific air consumption .....	3 NI

##### V-nail characteristics

V-nail type	Height mm
H3	3mm (optional)
H5	5mm
H7	7mm
H10	10mm
H12	12mm
H15	15mm



Material	Recommended sharpness
Soft woods and plastic	SW transparent stick
Medium wood	MW brown stick
Hard wood	HW green stick
Very Hard Wood and MDF	HS red stick



### 1.5. PRODUCTS PROCESSED - HANDLED OR GENERATED

The products handled by the machine described herein must be made up of wooden mouldings of various hardness, with multiple surface finishes, for the purpose of making frames for pictures, mirrors, display cases, cupboard doors etc..

The main technical characteristics of the products handled by the machine described herein are provided below.

#### DESCRIPTION OF PRODUCTS HANDLED

##### CHARACTERISTICS

Minimum/maximum width of moulding	6 / 60 mm - ¼" – 2"1/2
Minimum/maximum thickness of moulding	6 / 80 mm - ¼" – 3"1/4
Maximum length of moulding*	Without extensions: Length max=700 mm- 9/16 in; 10 Kg.
Weight	With extensions: Max. length =1700 mm - 11/16 in; Weight 25 Kg.

## 1.6. EMISSION OF AIRBORNE NOISE

 **NOTE** – The manufacturer declares, under his own responsibility, that the machine produces a continuous equivalent A-weighted sound pressure level of 72 dB.

 **DANGER – WARNING:**  
**TO AVOID THE DANGER OF HEARING DAMAGE CAUSED BY SHRILL OR INSISTENT NOISE, THE MACHINE OPERATOR AND MAINTENANCE TECHNICIAN MUST ALWAYS USE APPROPRIATE HEARING PROTECTION, SUCH AS HEARING DEFENDERS OR EARPLUGS.**

## 1.7. RESIDUAL RISKS - GENERAL INFORMATION

This manual contains a list and description of the residual risks that could not be eliminated in the design stage and that therefore remain present on the machine.

For each risk, suitable instructions or prescriptions are given which the user must observe in order to avoid hazards affecting the machine operator, maintenance technicians, any exposed persons and the machine itself.

## 1.8. RESIDUAL RISKS

### Residual risk due to noise

As demonstrated by experimental tests, the machine produces a continuous equivalent A-weighted sound pressure level of 72 dB. To avoid the risk of hearing damage caused by shrill or insistent noise during machine use, in addition to being adequately informed and trained, the operator and maintenance technician must always use appropriate hearing protection, such as hearing defenders, earplugs or similar personal protection equipment to safeguard hearing.

#### PPE to be used:



Hearing protection

### Residual risk due to the combustibility of the substances used in the machine and the products handled by the same

To avoid the hazards resulting from:

- the ignition of substances used in the machine,
- residual risks associated with possible outbreaks of fire,

the employer, in addition to training and adequately informing the machine operator and maintenance technician on such risks, must provide permanent fire protection systems in the vicinity of the machine control station. Said systems must be suitable for the types of material which could catch fire.

#### PPE to be used:



Protective gloves



Safety footwear



Safety clothing

### Residual risk caused by piloting the valves with a special tool

There is a residual risk for the maintenance technician, when the safety guards are open and valve piloting is activated using the special tool, in order to check (during troubleshooting procedures) the operation of the pneumatically operated mobile elements, when energy remains accumulated inside the actuator cylinders.

Consequently, when the aforementioned activities are performed, the maintenance technician must make sure that no exposed persons are found near the pneumatically controlled mobile elements and in any case said mobile elements must only be activated if strictly necessary for pinpointing operating faults.

### Residual risk due to the presence of accumulated energy inside the pneumatic actuator cylinders

There is a residual risk for the maintenance technician when the machine is isolated from the compressed air network, **due to the presence of accumulated energy inside the actuator cylinders**, when mobile guards are open caused by the presence of closed-centre valves and/or tanks which remain pressurized.

Please note that said piping is duly identified and indicated to distinguish it from all other piping installed on the machine.

Consequently, before carrying out any work on the aforementioned cylinders, in accordance with the instructions given in the actuator manuals supplied with the machine, the maintenance technician must neutralise the accumulated energy working in compliance with the safety regulations applicable to maintenance personnel, such as, for example, manual activation of the special tool for the piloting valves used to discharge stored energy.

Under no circumstances must the piping be disconnected if they still hold residual pressure.

### Residual risk of finger crushing

With the adjustable polycarbonate guard in the high or low position, there is a residual risk of finger crushing, for operators and maintenance technicians, inside the slot on the working bench along the stroke of the V-nail shooting unit.

Furthermore, it is to be pointed out that said finger crushing risks are present near each mobile element installed over the machine's working bench.

Consequently the operator and maintenance technician, as well as observing the instructions provided in this manual, must never place their fingers or any other part of the body in the zone indicated. What's more, workers must never wear rings, wrist watches, jewellery, torn clothing, scarves, ties or any other loose clothing or personal accessories that may constitute a risk. Make sure sleeves fit snugly around wrists and keep long hair tied back.

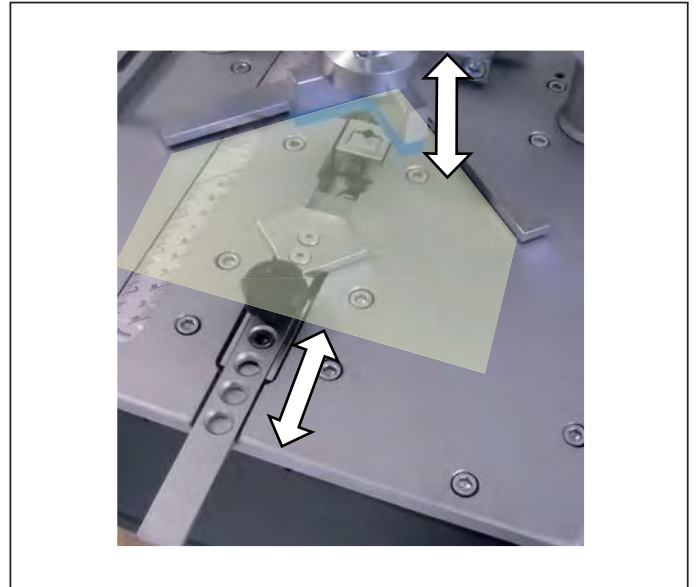

## 1.9. DESCRIPTION OF SAFETY FUNCTIONS

### Protective devices installed on the machine



#### **DANGER - WARNING**

**IT IS STRICTLY PROHIBITED TO REMOVE THE SAFEGUARDS AND SAFETY DEVICES EXCEPT WHEN STRICTLY NECESSARY FOR THE PURPOSE OF CARRYING OUT MAINTENANCE WORK.**

When such safeguards and safety devices need to be removed all necessary measures must be adopted to highlight this situation immediately and minimise any possible associated hazards.

The safeguards and safety devices must be refitted as soon as the reasons for their temporary removal are no longer applicable.

Each operating unit of the machine is protected by a guard, which may also be a fixed guard designed to prevent access to dangerous parts, except:

- in the upper part of the working bench to perform adjustments, tooling, parts replacement, etc.
- in the lower part of the working bench to perform adjustments, tooling, parts replacement, etc.

**Machine guards and safety devices**

Ref.	GUARDS / PROTECTIVE DEVICES – POSITION	TYPE OF SAFEGUARDED HAZARD
A	Adjustable guard	Polycarbonate panel secured to metal supports which can be adjusted by acting on the relative knobs, to prevent access to the stopper.
B	Fixed guard	Casing in welded sheet metal to support the working bench and prevent access to the pneumatic actuators housed inside the machine.

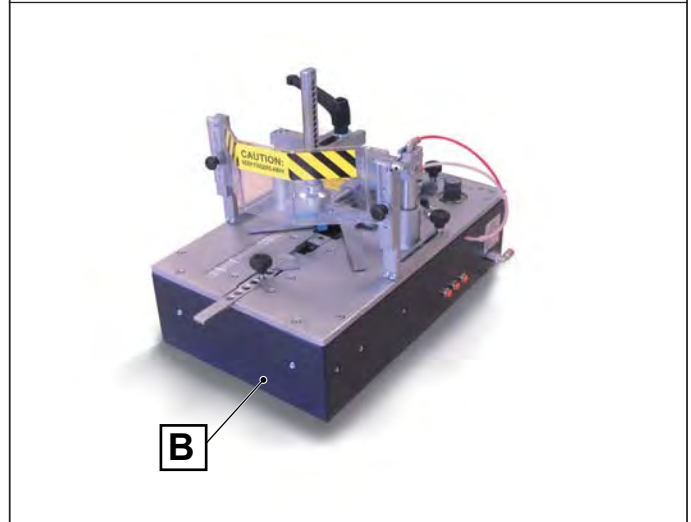

With regard to fixed guards the following specifications apply:

- The dimensions of fixed guards are such as to eliminate all openings to the protected dangerous work zone when the guards are correctly secured in place.
- Fixed guards that are not permanently welded to the machine are secured in place by screws that call for the use of special tools (Allen keys) and can only be removed, using the appropriate tool, by authorized maintenance technicians.
- access to areas protected by a fixed guard is allowed only for maintenance technicians. Irrespective of the circumstances, machine operators must never attempt to open a fixed guard.
- It is not possible to refit a guard incorrectly and leave potentially dangerous openings in the machine safeguards.
- If the guards are not fixed in their seats using the special screws, they will not remain lodged in their locations in the absence of the fastening elements.

In sizing and selecting the guards and safety devices, the possibility of access by persons aged 14 or over was used as a reference condition.

**! DANGER - WARNING**  
**ACCESS TO AREAS PROTECTED BY A MOVABLE GUARD IS ALLOWED FOR BOTH THE MACHINE OPERATOR AND MAINTENANCE TECHNICIAN. IRRESPECTIVE OF THE CIRCUMSTANCES, THE MACHINE OPERATOR MUST NEVER ATTEMPT TO VOLUNTARILY CIRCUMVENT A FIXED GUARD.**

- access to areas protected by a fixed guard is allowed only for maintenance technicians. Under no circumstances must the machine operator ever attempt to voluntarily circumvent a moveable guard.
- Before starting the machine, all guards and safety devices must be correctly installed, adjusted/tuned and made functional, adhering meticulously and carefully to the indications provided in the installation, use and maintenance manuals accompanying said safety devices (all of which are supplied with the machine) and this instruction manual.
- The manufacturer strictly prohibits any tampering, even partial or momentary, with any of the safety devices present on the machine, because they are installed specifically to ensure the physical safety of operators and other persons present in the machine operating area.
- Violation of this regulation will give rise to risks and is in conflict with statutory legal regulations concerning safety in the workplace.

### 1.10. DESCRIPTION OF THE MACHINE

THE U300 FRAME ASSEMBLING MACHINE is a machine for producing wooden, PLASTIC AND mdf frames. More specifically it joins together the frame mouldings (which may be pre-glued or dry) using metal V-nails.

All operating phases such as: loading and unloading of the frame, clamping, head movement and nailing are completely manual.

The machine can use special Alfagraf V-nails with "Pulling Power" effect or universal V-nails.

In its basic configuration the machine is made up of a rigid steel structure, complete with base and a series of operating units and zones:

#### 1 working bench, complete with:

- a single stopper device for immobilizing the mouldings (A);
- a device for front clamping of the mouldings (B);
- a system of alignment fences (C);
- a V-nail firing unit (D);
- a system for locking the alignment fences (AFC brake) (E);
- a series of pneumatic actuators.
- EC safeguard (F).

#### 1 stand

- a series of adjustable feet for machine levelling;
- a tilting support

MACHINE FUNCTIONS are controlled manually by the operator who directly activates the pneumatic actuators.

The figure alongside shows the machine in its basic configuration, mounted on stand (optional), with mouldings clamping system, mobile fence and pedal.

If purchased without the stand, the machine can be placed on a sturdy, level and stable work bench.

The references and photos used in this manual refer to the machine with stand so that all aspects are fully covered.

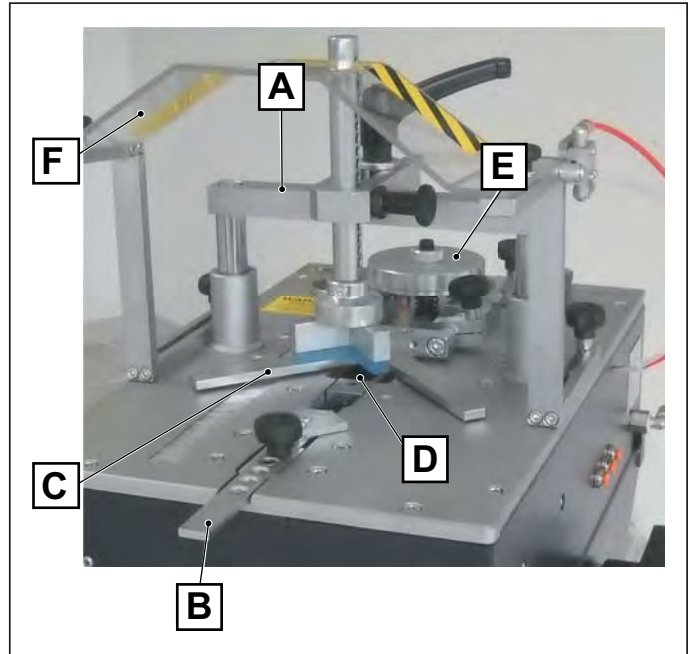

### 1.11. MAIN MACHINE COMPONENTS

In its basic configuration the machine is made up of a series of operating units and zones, including:

- (G) Working bench
- (H) Stand (optional)
- (I) Pneumatic pedal switch
- (L) Machine casing
- (M) External compressed air connections, pedal and power supply

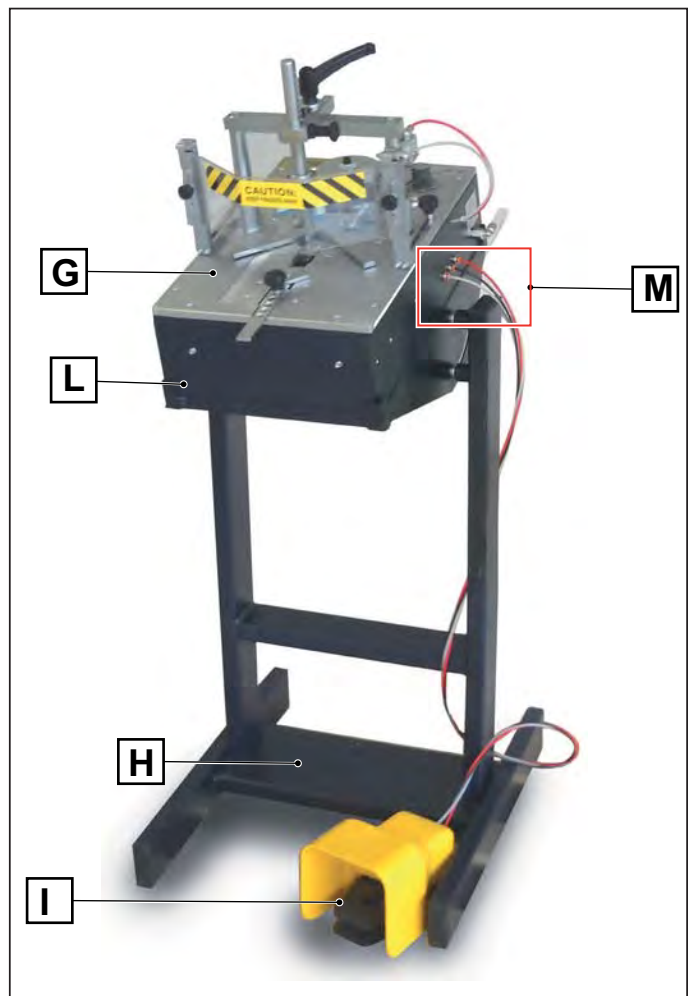

**Working bench**

The working bench is the surface on which manual operations take place to move, clamp and join the frame mouldings and holds all the operator controls.

It is made up of the following main parts:

- (A) Vertical moulding clamp unit
- (B) Alignment guides unit
- (C) V-nail firing unit and magazine
- (D) Front moulding clamp unit
- (E) AFC brake
- (F) Clamping units air pressure adjustment
- (G) Alignment guide movement travel stop adjustment unit
- (H) EC safeguard

**Vertical clamp unit**

This unit is designed to immobilize the mouldings on the working bench and counteract the V-nailing force.

Its position ensures that the stopper is aligned with the firing head and is therefore in line with the direction of V-nail insertion.

It is important that the air pressure applied to the vertical clamp provides thrust which is always higher than the thrust of the V-nails, if this is not the case, V-nail insertion could result in the mouldings being lifted up, resulting in incomplete insertion of the V-nail and a poor quality join.

The unit is made up of a mechanical or magnetic stopper holder to which the interchangeable rubber stoppers (P) of varying hardness are applied, located at the bottom of a punched column (N) which can be positioned at various heights depending on the size of the frame.

The assembly is fastened to two sturdy columns (S) the movement of which is controlled by pneumatic actuators. The punched column is installed on a support (R) which makes it possible to carry out horizontal adjustment of the stopper along the line of assembly.

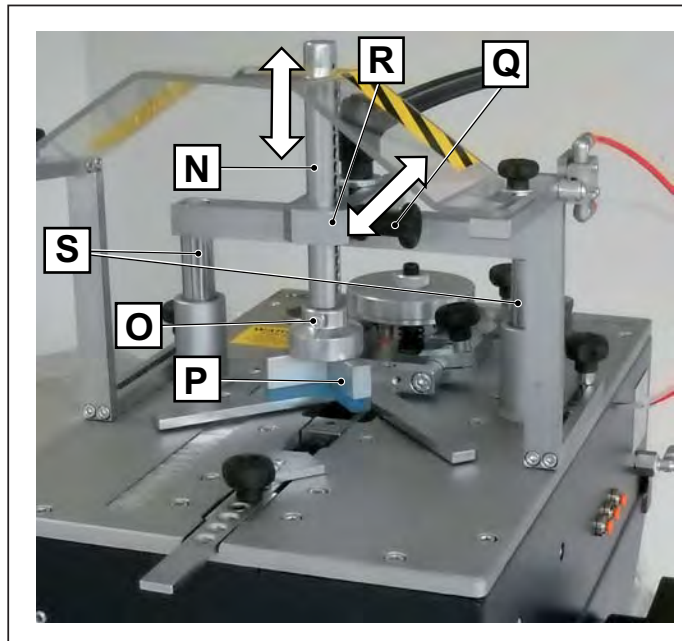
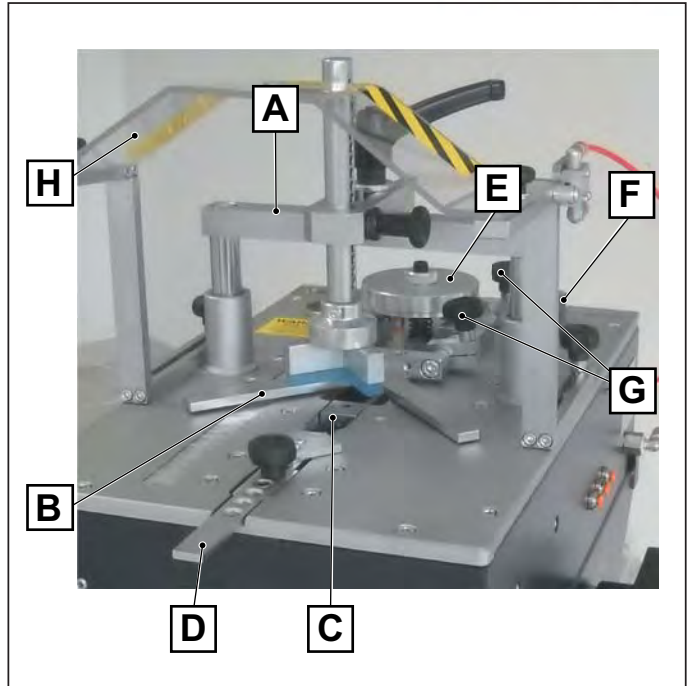

The vertical stopper unit is made up of the following main parts:

- (N) Punched rod - allows the operator to position the stopper at various heights based on the various frame profiles.
- (O) Screw for fastening and for rapid changeover of the mechanical stopper holder or the magnetic support;
- (P) Stopper holder, which may be mechanical or magnetic depending on the type of accessories used.
- (Q) Click knob for blocking the column.
- (R) Rod support arm.
- (S) Piston stem vertically activated by the pneumatic actuator.

**Stoppers available on request:**

- T) Mechanical stopper holder.
- U) Interchangeable stopper - soft (blue).
- V) Interchangeable stopper - medium (yellow).
- W) Interchangeable stopper - hard (black).
- X) Round magnetic felt stopper.
- Y) Corner magnetic stopper holder.
- Z) Magnetic support.

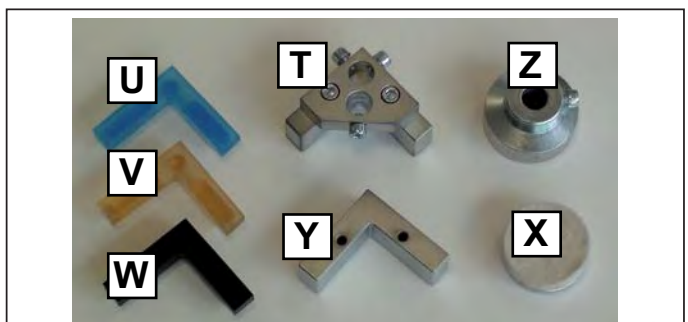

### V-nail magazine and V-nail firing head

In the U300 machine, the magazine (E) can hold V-nails of different heights but only one V-nail height can be used at a time, depending on the nailing head installed.

When the size of the V-nails is changed the nailing head must also be switched over to match the V-nails used.

The V-nails are held in position by the V-nail pusher device (F).

Head and L-block support are designed to guide the V-nails during the thrust action of the hammer and their insertion into the overlying mouldings.

The magazine is in turn brought up against the L-block support and by means of a V-nail pusher supplies and aligns the V-nails against the guide each time the hammer is activated.

The hammer is activated by a pneumatic cylinder which is controlled by the pneumatic pedal.

Perfect mechanical alignment of these parts ensures precise insertion, single or multiple, of the V-nails in the mouldings to be joined, in the quantity and with the spacing required.

- (A) Screw for fastening the head.
- (B) Head of different heights.
- (C) L-block support
- (D) Hammer
- (E) V-nail magazine
- (F) V-nail pusher which keeps the V-nails at a constant pressure up against the firing unit.
- (G) PLV selector lever:  
in the OFF position (open) it draws the V-nail pusher back so that V-nails can be put in the magazine;  
in the ON position (closed) the V-nail pusher pushes the V-nails against the firing unit. When in the OFF position, all clamping and firing commands are deactivated and the pedal does not work.

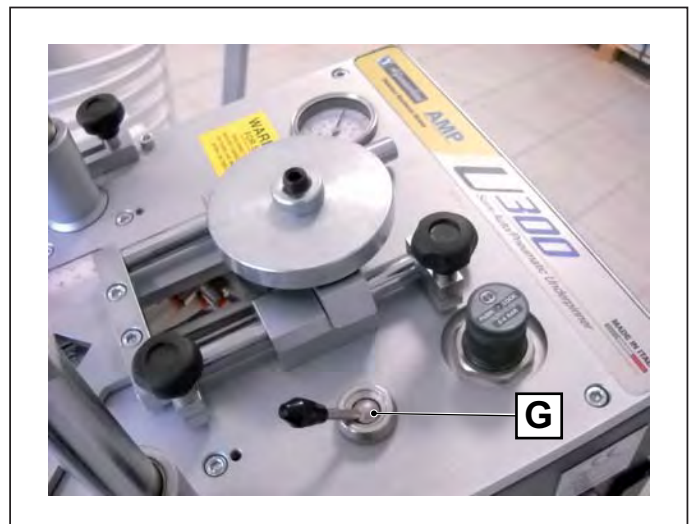
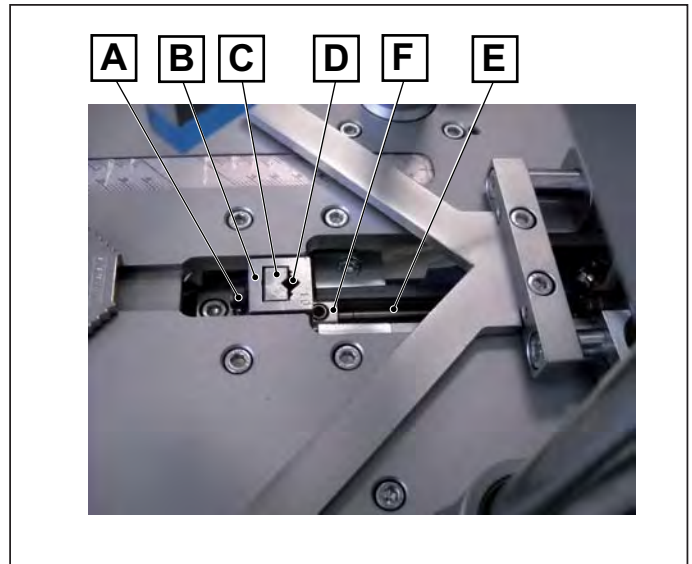

In the U300 machine, the magazine (E) can hold V-nails of different heights but only one V-nail height can be used at a time, depending on the nailing head installed.  
When the size of the V-nails is changed the nailing head must also be switched over to match the V-nails used.  
The V-nails are held in position by the V-nail pusher device (F).

**Alignment guides unit**

The alignment guide unit, positioned on the working bench, can slide along the assembly line of the firing unit. Its position is adjusted by the operator based on the size of the moulding in relation to the position of the front clamp (rod clamp).

Fixed fences for 120° and 135° corners may also be installed in the fence support (A) for making frames with 6 and 8 sides respectively (available as optional accessories).

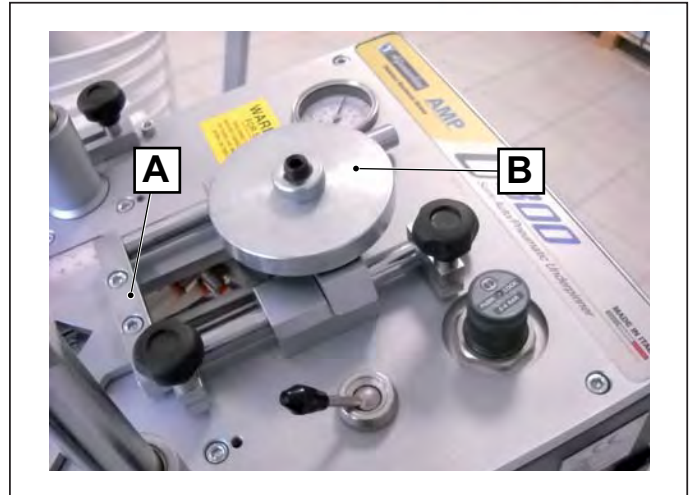

**AFC brake unit**

The AFC brake unit (B) is made up of a pneumatically activated device which comes into operation during the nailing cycle.  
The unit is designed to lock the position of the mobile fence and oppose the horizontal thrust of the rod clamp.

**Two-knob fence (optional)**

The fixed fence can be replaced with the two-knob model (C) which allows the user to adjust the tilt of the moulding stop in relation to the work bench.  
Mouldings may have a slanting edge which would make the action of the horizontal clamp ineffective. The two-knob fence is designed to include tilt adjustment of the surface against which the mouldings rest to improve stability.  
The two-knob fence can be used to improve clamping of the mouldings during assembly.

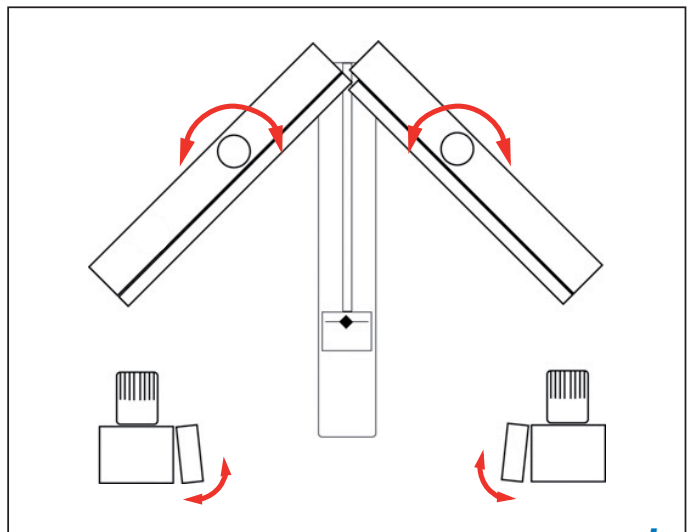
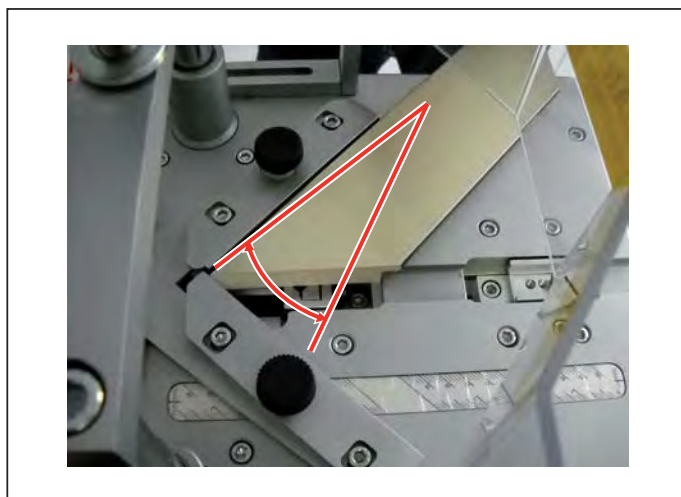
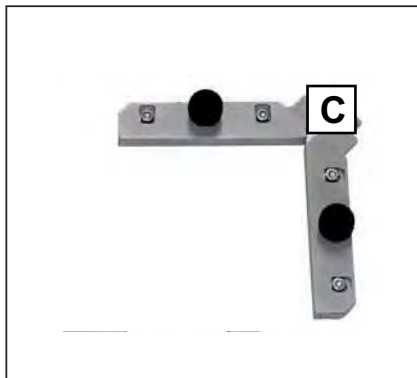



### **Horizontal blocking (rod clamp)**

The rod clamp (L) is fitted with a jaw (G) which is moved forward against the internal corner of the mouldings when the operator presses the pedal thus clamping them against the fence unit.

Movement of the rod clamp occurs at the same time as vertical clamping and is activated by a pneumatic actuator when the pedal is pressed. For as long as the pedal is pressed, it clamps the mouldings for the entire duration of the nailing cycle.

The position of the rod clamp must be adjusted according to the position of V-nail insertion and the size of the mouldings to be joined.

The front clamp is made up of:

- (G) Fixed jaw.
- (H) Knob for securing the rod to the pneumatic actuator of the front clamp.
- (I) Holes for anchoring the cursor of the pneumatic actuator.
- (L) Front locking rod clamp

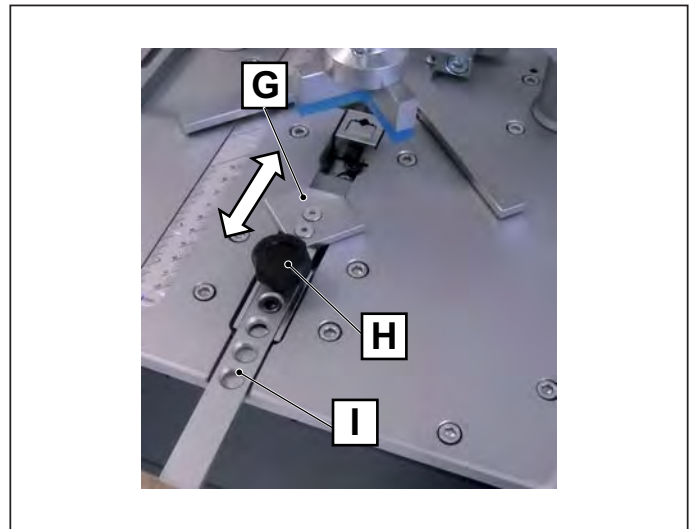
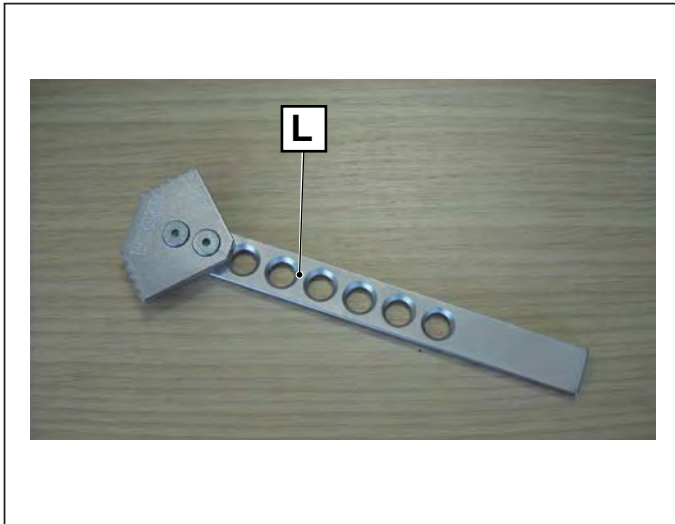

### **Work surface extensions (optional)**

For joining up mouldings exceeding 700 mm in length the working bench needs to be increased by installing the two side extensions (A) and (B) (optional).

The extensions are fitted to the sides of the machine. They must be perfectly aligned with the working bench, see heading ASSEMBLY OF SEPARATELY SHIPPED UNITS.

- (A) Right extension
- (B) Left extension.

The machine is designed to be STATIC, i.e. it must be installed on the floor or anchored to the floor or other parts of the building structure so that it remains stationary during operation.

If detached from the stand, the machine can be used on a horizontal, sturdy and stable table.

The machine is LOADED AND UNLOADED MANUALLY:

- i. MANUAL POSITIONING OF THE MOULDINGS to be assembled on the working bench, with the fixed guards closed and locked
- ii. MANUAL REMOVAL OF THE ASSEMBLED MOULDINGS from the working bench, with the fixed guards closed and locked.

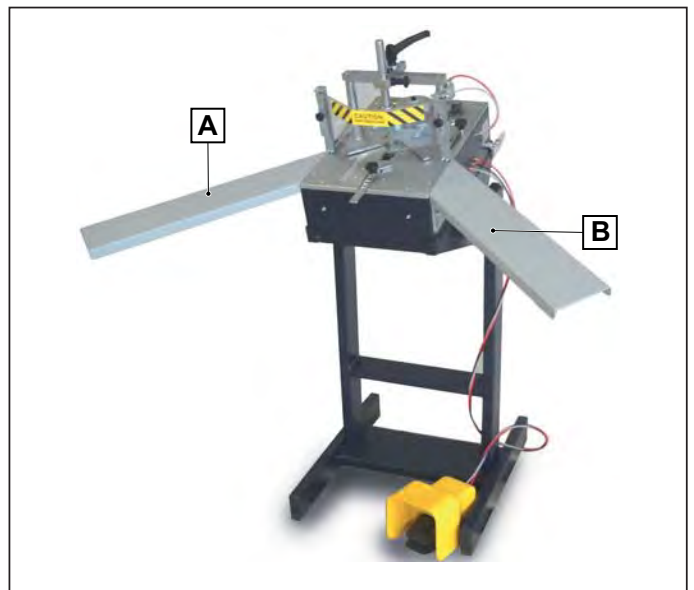

### **Brackets for extending the work surface (not supplied)**

To extend the available work surface for the mouldings, it is possible to install 6 brackets (C), 2 on each side, onto which a surface panel in wood or other material (not supplied) is placed.

To install the brackets, please refer to the heading ASSEMBLY OF SEPARATELY SHIPPED UNITS

- (A) 90° bracket with slots and holes for fastening to the machine and the wooden surface panel.

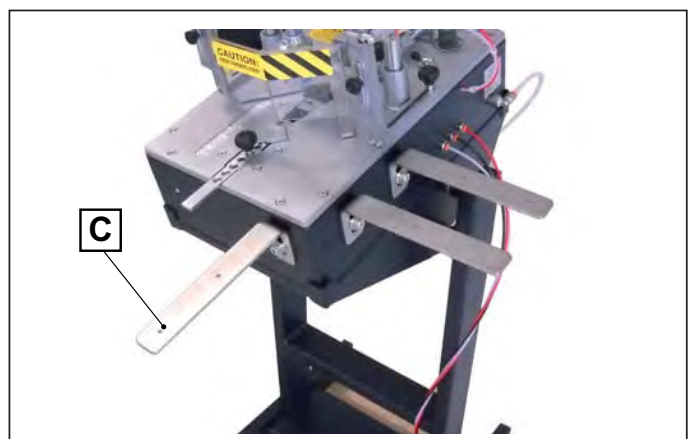

## 2. INSTALLATION

### 2.1. STORAGE

The machine, intended for indoor installation must be stored, if necessary, in well ventilated storage facilities and protected from dust. The delivered elements must remain in their original packing until the time of final installation. All parts of the machine subject to the risk of oxidation are protected with grease and protective sprays at the time of dispatch to prevent oxidation caused by weather conditions.

In the case of prolonged inactivity the machine must be stored with all necessary precautions taken based on the location and expected storage times:

1. Store the machine in an enclosed place.
2. Protect the machine from impact and stress.
3. Protect the machine from humidity and excessive temperature differences (refer to the table below).
4. Do not allow corrosive substances to come into contact with the machine.
5. Check that the pack has not been damaged and that it is perfectly dry.
6. Specifically, if the machine is inside a shipping container, the storage area must be covered and protected against direct weather including rain, snow and hail, and it must be accessible exclusively to authorized personnel.

The machine is protected in such a way as to withstand the temperatures, humidity and vibration levels typically associated with transport and storage.

Ambient temperature	-25 ÷ +40°C - 13 ÷ 104°F	Avoid places where there may be unexpected changes in temperature which could lead to the formation of condensate or freezing.
Storing temperature	-25 ÷ +55°C - 13 ÷ 131°F 0 ÷ +55 °C / 32 ÷ 131°F	
Relative humidity	100% at a temperature of +25°C / 77°F Lower than 50% at a temperature of +40°C / 104°F	
Vibrations	Lower than 90% at a temperature of +20°C / 68°F	
Atmospheric pressure	5.9 m/s <sup>2</sup> (0.6G) or higher 900 mbar or more	

Storage temperature is construed as a short-term value, e.g. during transportation. Condensation or freezing normally occurs in sites subject to significant temperature excursions. Even if relative humidity in such conditions falls within the values shown in the table, locations subject to significant temperature changes should be avoided.

### 2.2. CHECKS ON RECEPTION



#### NOTES

*It is essential to check the packs at the time of arrival and in the precise moment in which they are received. The check is performed in two stages for each pack received to avoid misunderstandings with the shipping agent.*

#### Administrative check

1. Crate number and number of packs.
2. Weight and size
3. Correspondence of information on shipping document with the material effectively delivered (description, serial number, etc). The technical data given on the machine identification plate must correspond with the data given in the technical data supplied).
4. Check correspondence between shipping document data and the order.

#### Technical check

1. Condition and intactness of packaging.
2. Check that the packaging shows no signs of visible damage caused during transport and handling operations.

All the above checks must be performed by inspection in the presence of the shipping agent's delivery person. If any damage is noted or the supply is incomplete or incorrect, inform the manufacturer's sales department immediately.



#### NOTES

*In relation to the above prescriptions, the manufacturer informs the user that in compliance with current international and national rulings, goods are always shipped at the risk and responsibility of the purchaser and, unless otherwise stated in writing at the time of the order confirmation, freight travels without insurance cover.*

**2.3. TRANSPORT, LIFTING AND HANDLING**

Dimensions, weight and handling of individual machine parts

**MACHINE BODY**

Machine height .....	A = 1340mm - 53"
Machine length .....	B = 600mm - 24"
Machine width .....	B = 500mm - 20"
Weight of the machine .....	35kg - 77 lbs
Weight of the stand .....	30 kg - 66 lbs
Size of the packaging.....	600x440x500

**2.4. LIFTING AND HANDLING**

**! DANGER – CAUTION**

- The machine must be transported to a position as close to the intended installation site as possible. Said site must be checked beforehand to obtain information about the necessary clearances and dimensions, including the essential space required for installation procedures.
- It is strictly prohibited to lift loads over people. If persons are present in the area, lower the load and ensure everyone moves out of the way.

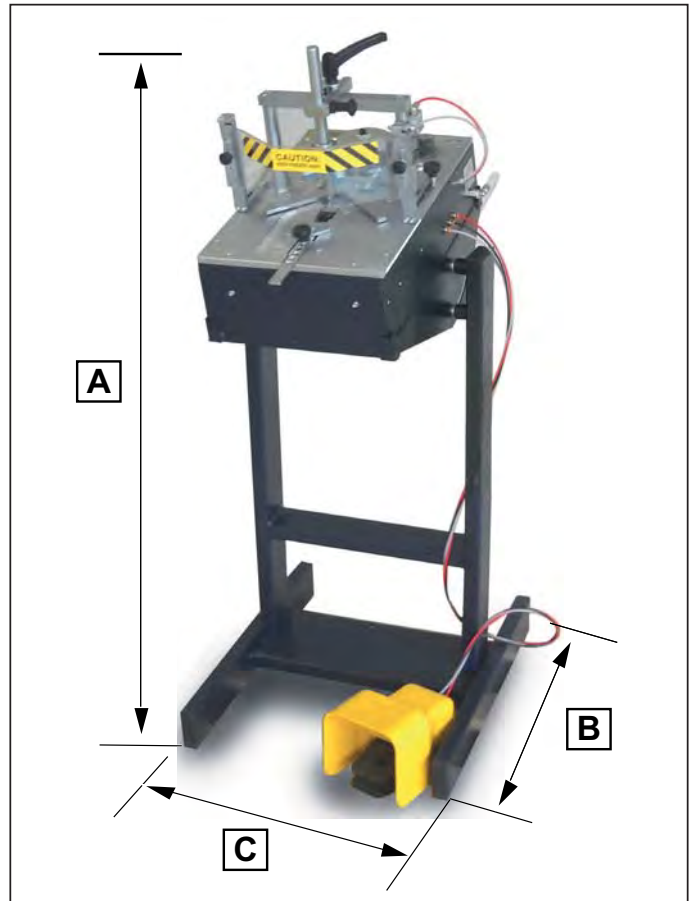

**2.4. LIFTING AND HANDLING**

The U300 is divided up and delivered as an assembly kit. The box dimensions are: (660x440x500)mm. (see figure) Transport must be carried out by professionally qualified personnel. The machine must be transported in such a way as to avoid any damage to its components:

- The machine must be transported in its installation position.
- Before transporting the machine, grease all non-painted parts to avoid the risk of deterioration.
- Based on the type of transport, take care to protect the machine from all possible impact and stress.

**NOTE** – The machine must be lifted by TWO operators.

**NOTE** –It is advisable to keep the packaging in case it is needed to store or transport the machine at a later date.

The machine is moved on a two-wheel trolley.

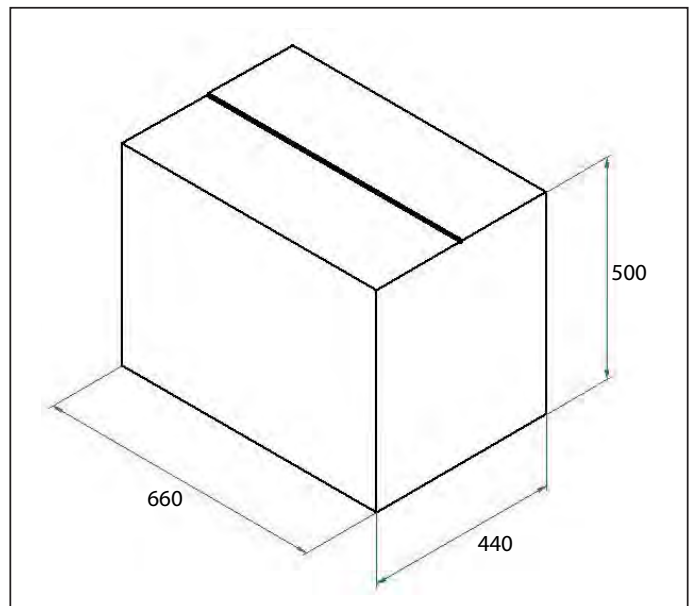

### **MULTIPLE TRANSPORT AND HANDLING**

The transport of more than one machine can be carried out using a Europallet which can carry up to a maximum of 12 boxes (12 machines).

**Overall dimensions** = (80x1200x1800mm - AxBxC).

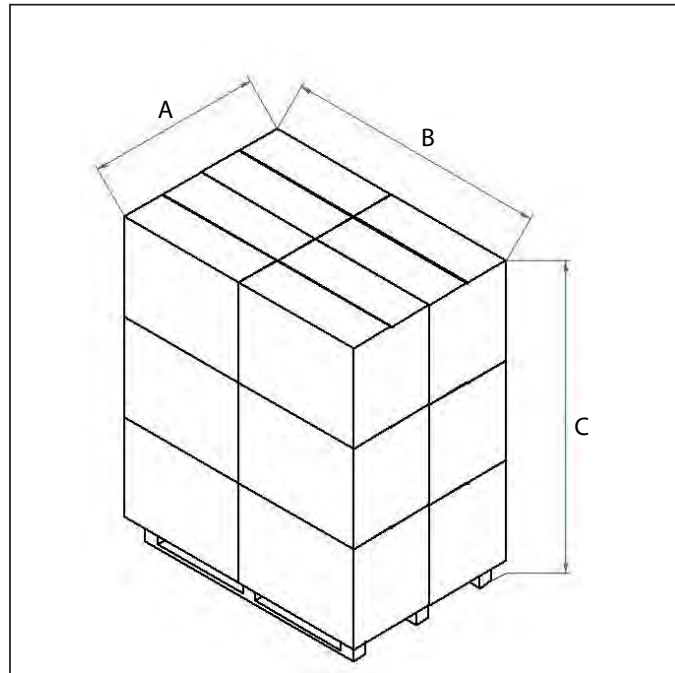

### **2.5. REMOVING THE PACKAGING**

#### **Description of the packaging**

The machine may be shipped in a container or on a lorry.

In both cases the same type of packing is envisaged which is suitable for guaranteeing the good condition and proper preservation of the machine during transport up to the time of delivery to the customer.

The machine is shipped packed in a special box and protected against damage by polystyrene inserts.  
Maximum dimensions 660x440x500 (AxBxC).

 **NOTE** –It is advisable to keep the packaging in case it is needed to store or transport the machine at a later date.

When storing the machine, never stack two machines packed on a pallet with shrink wrap.

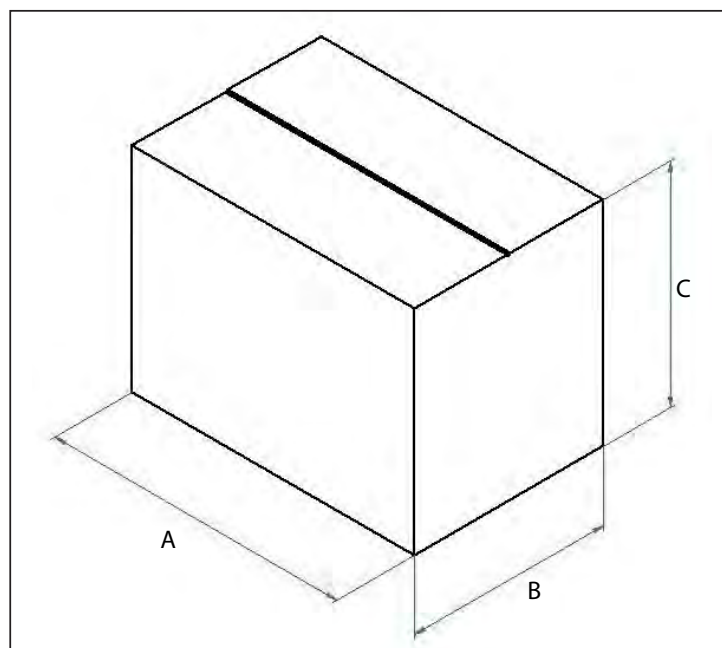

The various packing materials must be disposed of in compliance with the relative legislation in force. Seek advice from the delegated authorities and/or the assistance of specialist companies authorised to dispose of pollutant or recyclable waste products.

**! DANGER – CAUTION**

**Warning – pollution hazard: do not dispose of the packing material in the environment; retain it for future transport uses or consign it to a recycling company. Evaluation and management of the packing materials in terms of biological compatibility are the duty and responsibility of the user.**



### 3. PRELIMINARY PREPARATION AND ADJUSTMENT PROCEDURES

#### 3.1. POSITIONING

##### Suitability of the floor – supporting surface

The machine must be positioned on a solid, reinforced concrete foundation.

The floor must have an adequate load bearing capacity to support the weight of the machine. The floor must be designed and prepared by the user.

##### Preparation on site

The machine layout is provided as an attachment to this manual. It is complete with the necessary data for positioning on the factory floor. THE PLACE IN WHICH THE MACHINE IS USED must be clean and free of obstacles (see figure).

TO ALLOW FOR EASY REMOVAL OF THE MACHINE FOR MAINTENANCE it must be positioned in a place having the surface dimensions indicated in the figure.

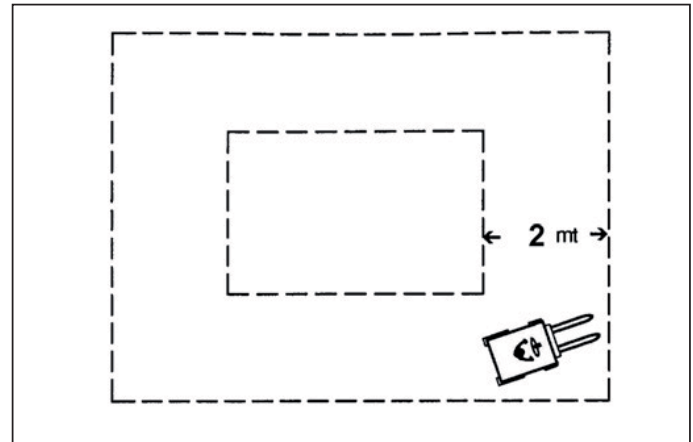

#### 3.2. LEVELLING THE MACHINE

Stability of the machine is designed in such a way that, in the specified conditions of operation, it can be used without risks of overturning, falling, or uncontrolled displacement.

In order to avoid mechanical stress during normal use of the machine and undue strain to the structure, the machine must be stabilised during lifting operations.

The standard machine is supplied ready assembled on the stand which is secured to a pallet (A).

Unscrew the 4 screws positioned under the pallet to remove the machine. Install the 4 feet (B) using the relative wrench. It is important to stabilize the stand by turning the threaded pin on each support foot (C) by means of the special wrench.

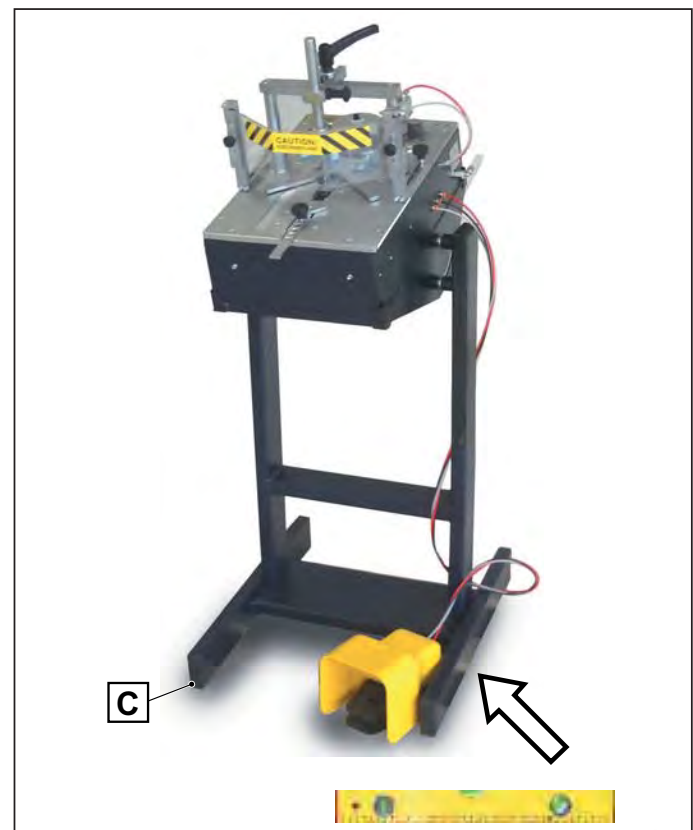
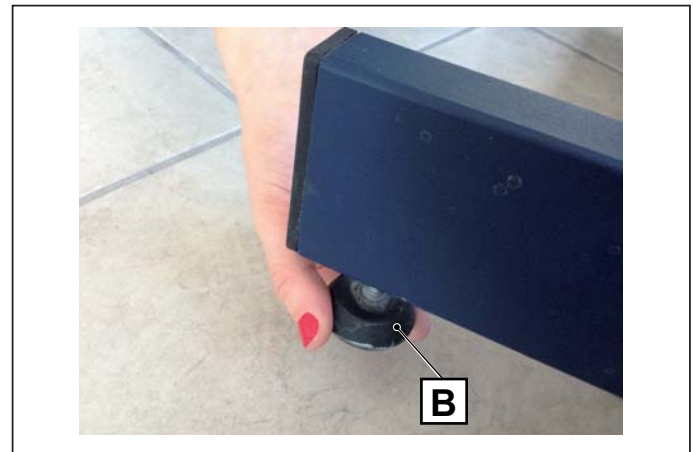

### 3.3. ASSEMBLY OF SEPARATELY SHIPPED UNITS



#### **DANGER – CAUTION**

*All assembly activities concerning machine units supplied separately, include highly delicate operations which call for significant experience. Consequently they must be carried out exclusively by personnel appointed directly by the manufacturer or authorised by the same and, in any case, under the manufacturer's responsibility. These activities are therefore the sole responsibility of the machine manufacturer's personnel.*

#### Installation of working bench extensions (optional)

The working bench extensions are optional and may be requested from the manufacturer.

Their installation requires precise alignment between the working bench and the extensions so that the lower surface of the mouldings rest fully on the entire support surface when the double stopper presses down on the ends of the mouldings.

To install the extensions proceed as follows:

1. Unscrew the grub screws located on the left- and right-hand sides of the machine.
2. Place the right and left extensions alongside the machine accordingly.
3. Insert the fixing screws and align the extensions. Finally, tighten the screws.

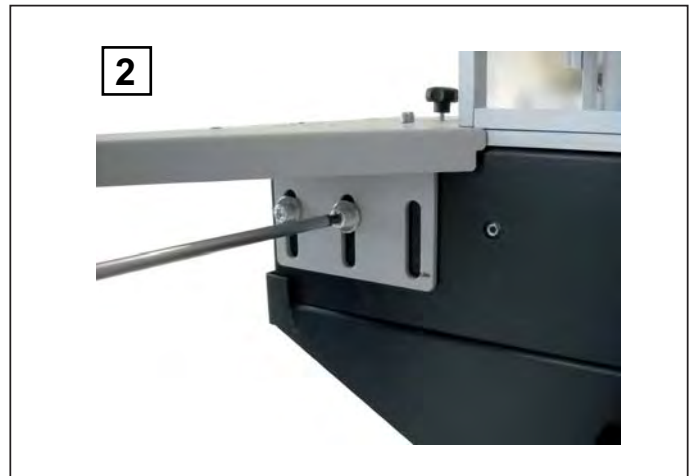
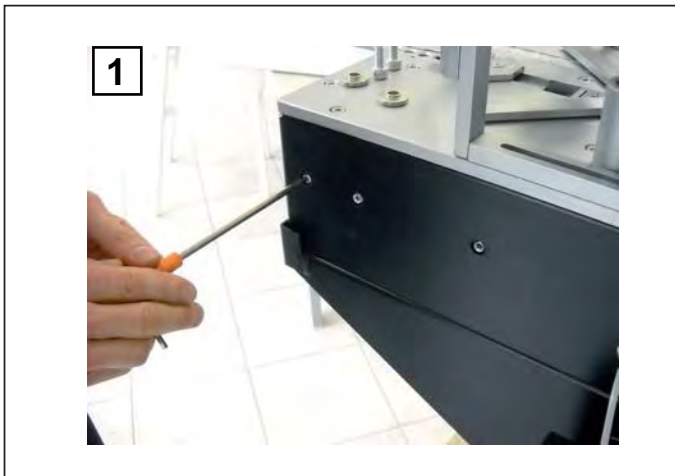

### **Installation of the bracket system for the wooden work surface (not supplied)**

The wooden work surface (not supplied) and the working bench must be aligned carefully so that the lower surface of the mouldings rest fully on the entire support surface when the double stopper presses down on the ends of the mouldings.

The machine casing is fitted with special holes for fastening the brackets to support the work surface (not provided).

An example of how to install the brackets is provided below.

To install the extensions proceed as follows:



1. Check that each of the 6 brackets comes with the components shown in the photo.



2. Remove the grub screws from the machine body.

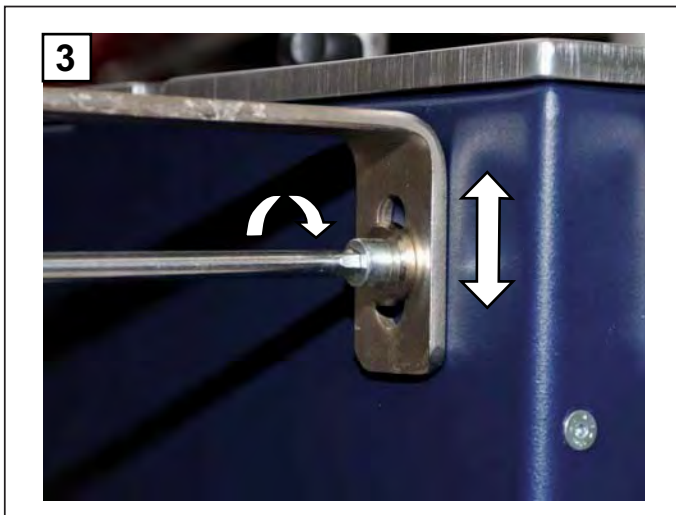

3. Insert the washer with spacer and the socket head screw in the slot on the bracket. Do not tighten until the work surface has been installed and the height duly adjusted.

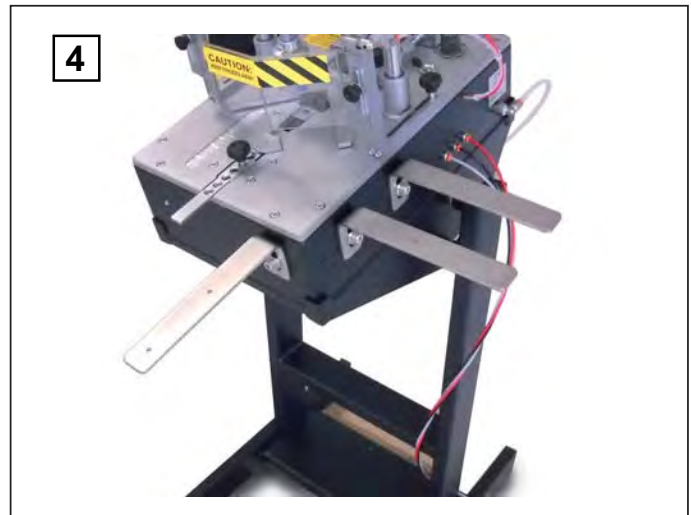

4. After having installed the six brackets, place the wooden work surface on them and adjust the height of each bracket.



**Stand assembly**

Installation can be completed in a few simple steps as described below:

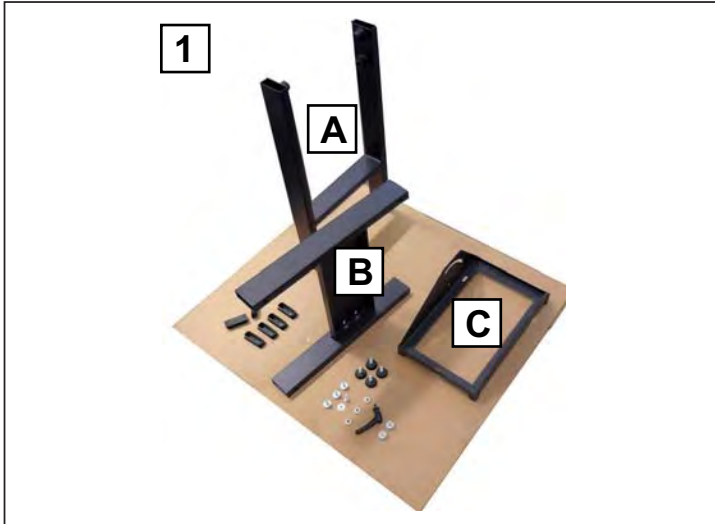

1. Proceed with assembly by joining the base (B) to the uprights (A) and the cradle fitted with supports (C).



2. Join the base to the uprights using the 4 screws provided.



3. Screw the four support feet into the base of the stand and fit the caps.



4. Add the cradle (D) by inserting the supports on the uprights



5. Adjust the height.

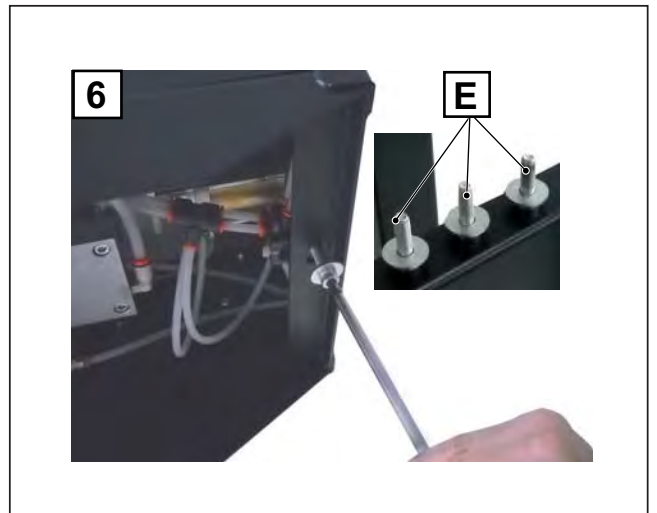

6. Position the machine on the cradle and fasten in place by inserting the three socket head screws (E) as indicated by the arrows.

### 3.4.2. Compressed air supply

The compressed air supply must be maintained in compliance with the following technical prescriptions:

- The compressed air supply must be of the type and intensity specified on the first page of the “pneumatic diagram”. If excessive pressure values are applied the components will be irreparably damaged.
- taking into account the fact that the machine’s pneumatic system is construed as a component of the distribution network, in the context of protection against overpressure, a protection device must be installed coordinated with the machine’s pneumatic circuit, in compliance with legislation and the legislative and regulatory provisions in force in the country of installation.
- The pneumatic system compressed air supply lines must be routed through the spaces provided by the user and must be adequately protected.
- The compressed air supply line must have a section and characteristics corresponding to the specifications shown on the first page of the “pneumatic diagram”. Pipelines of different sections to those specified can alter pressure values and therefore impair correct operation of the machine.

The following units are incorporated in the compressed air inlet point:

#### Standard supply:

- (A) Quick-fit coupler.



#### Pneumatic pedal hook-up

Before connecting the machine to the pneumatic system, you must first connect up the control pedal.

The three air lines which are connected to the pedal assembly must be inserted in the three connectors located on the right-hand side of the machine in the following order:

- 1) RED line in the connector on the outer side (1).
- 2) BLACK line in the intermediate connector (2).
- 3) TRANSPARENT line in the connector on the operator side (3).

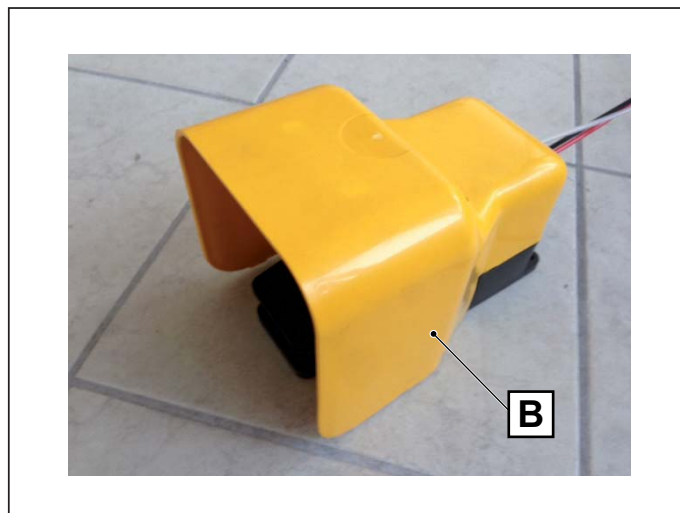
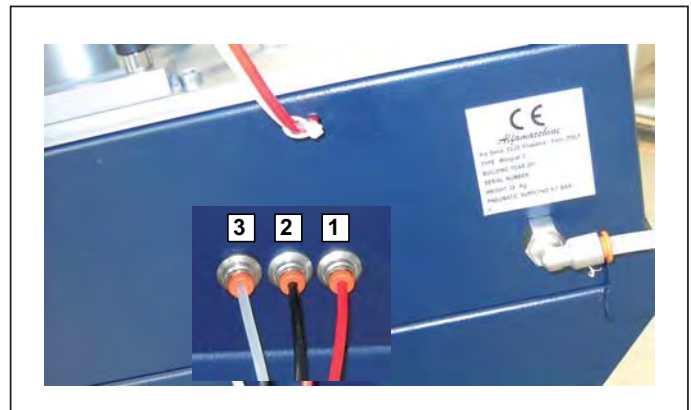

## User's compressed air production system

The compressed air production system must be designed, installed and maintained in compliance with the applicable prescriptions indicated in the safety regulations in force.

To high obtain quality compressed air, note that:

- maintenance and operation of the compressors, the auxiliary systems and the primary systems must be in compliance with the manufacturers' instructions and specifications;
- the lubricant must comply with the specifications given by the compressor manufacturer;
- the compressor or its suction line must be positioned in an area having the lowest possible level of pollution from vehicle exhausts, fumes exhaustion from industrial processes, etc.
- a filter should be installed on the compressed air line as close as possible to the user point.

### **Air quality:**

- To obtain the best possible performance and the maximum lifetime of the pneumatic system use compressed air having a dew point between +2°C and + 10°C.
- use a separate air filter, installed as close as possible to the user point. Flush the line with compressed air before connecting it.

For correct use of compressed air, in general terms, consult the following reference standards:

- ISO 8573 – 1, this standard defines the industrial compressed air quality for general use without considering the quality of air at the compressor outlet.
- The compressed air quality level for special applications must be based on the value resulting from a large number of measurements taken during a specific time period and in clearly defined operating conditions.

For the required minimum pressure value, the nominal working pressure and the air consumption expressed as the average value for correct operation of the machine, refer to the heading "TECHNICAL CHARACTERISTICS".

### **Pneumatic power disconnect device**

The compressed air isolation device, as can be seen in the "pneumatic diagram" supplied with the machine, is supplied for the sole source of the machine compressed air supply and is of the "isolating shut-off valve" type. This device is identified with the wording, visible in normal conditions of use, "PNEUMATIC SUPPLY ISOLATOR DEVICE".

The unit is located outside the machine's base.

---

## **4. INITIAL START-UP AND USE OF THE MACHINE**

---



### **DANGER - WARNING**

**THE MACHINE MUST ONLY BE OPERATED BY AUTHORISED AND DULY TRAINED PERSONNEL WITH ADEQUATE TECHNICAL EXPERIENCE.**

**MACHINE OPERATORS MUST BE AWARE OF THE FACT THAT KNOWLEDGE AND IMPLEMENTATION OF THE SAFETY RULES ARE AN INTEGRAL PART OF THEIR WORK.**

**UNQUALIFIED PERSONNEL MUST NOT BE ALLOWED ACCESS TO THE MACHINE'S OPERATING AREA WHILE IT IS IN USE.**

Before switching on the machine, operators should:

- carefully read all the technical documentation
- know which protective equipment and emergency devices are available on the machine, where they are located, and how they work

The partial removal of safety guards and warning signs is forbidden.

Unauthorised use of commercial parts and accessories belonging to safety guards and safety devices can result in malfunctions and the occurrence of hazardous situations for operators.

Before starting the production cycle, the operator must be thoroughly familiar with:

- The position, function and use of all controls.
- The position, function and use of all safety devices.
- The machine's characteristics.
- This manual, and know how to consult it.

The operator must also have been appropriately trained.

#### 4.1. WORKSTATIONS AND OPERATORS' TASKS

The machine described herein is designed to be run by 1 operator suitably trained and instructed with regard to residual risks. The operator must have the same skills, in terms of safety, as the maintenance technicians and adequate professional competence.

The normal work area of the operator and relevant tasks/assignments are:

- The manual introduction/removal of mouldings onto the working bench, with the fixed safety guards closed and locked.
- The manual loading of V-nails in the magazine, with the fixed safety guards closed and locked.
- The adjustments and tooling of the key units (head, frontal clamp, alignment fences, etc.) needed to operate the machine, using the relevant tools, with the fixed guards closed and locked.
- The manual removal of V-nails clogged in the magazine and/or nailing claw head, with the fixed safety guards closed and locked.
- Check operations (for example reading the data on the console panel and machine instrumentation). These are very simple tasks which can be carried out in total safety and clearly described in the Instruction Manual.
- General monitoring of machine operation - for example checking the cleanliness of the machine, etc. In the event of a problem, the operator must not intervene, but simply call the Maintenance Service.
- Cleaning external and internal machine parts, and any other parts that may require cleaning (e.g. the upper/surrounding part of counter-rotating rollers) via the fixed safety guards, while these are closed and locked. Any cleaning of internal machine parts which requires the removal of the fixed guards must be performed by a qualified maintenance technician.

The operator is responsible for the operating process, and must control the machine by means of the command actuators located on the control panels.

Apart from normal machine operation, the operator must also start and stop the machine in normal conditions, and stop it in emergency conditions.

The operator must also carry out checks and general monitoring operations while the machine is running. In the event of a problem he/she must not intervene, but simply call the Maintenance Service.

All operations performed by the operator must be carried out with all protection devices activated, all guards in place, and all safety devices engaged in order to prevent the risk of injury to arms, legs and other body parts.

All handling operations, preparation, adjustments, installation and connection of power supplies, along with fine-tuning and operating checks, must be carried out by trained, skilled maintenance personnel.

All maintenance and control operations must be carried out by trained and skilled maintenance personnel.

All installation and hook-up operations must be carried out using suitable equipment and tools of an appropriate size (e.g. a flathead or Phillips screwdriver, hex wrenches, Allen keys, etc.), depending on the type of fasteners.

Before carrying out any installation or hook-up operation, the machine, the on-board components must be thoroughly cleaned.

**! DANGER – CAUTION**  
*Unless otherwise specified in the contract and clearly indicated in the technical specifications of this Manual, the machine is not suitable for use in environments different to those permitted and duly specified in this Manual.*

The main hazardous work areas of the machine, that may produce risks for the operator, are:

- The area beneath the stopper, inside the magazine and near the head.
- the area in front of the rod clamp;
- the area around the cursor of the rod clamp if removed;
- The area inside the machine during adjustment, tooling and cleaning operations.

Schematic indications of the danger zones for machine fitters:

- A. area under the stopper;
- B. area in front of the rod clamp;
- C. area around the rod clamp cursor if removed.

#### 4.3. CHECKS, ADJUSTMENTS AND START-UP

All functions/operations pertaining to operating modes must always comply with safety measures and the prescriptions for the protection against residual risks.

During normal production, the machine must only be used to process the products specified herein.

During the working cycle, it is essential to comply with safety measures and prescriptions for the protection against residual risks.

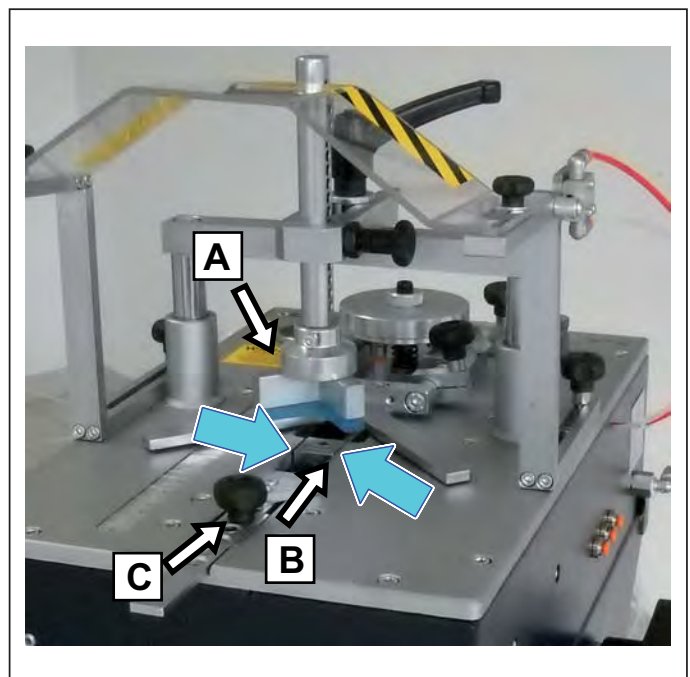

#### 4.4. START-UP

Before connecting the machine to the pneumatic system, you must first connect the control pedal.

The three air lines which are connected to the pedal assembly must be inserted in the three connectors located on the right-hand side of the machine in the following order:

- 1) RED line in the connector on the outer side (1).
- 2) BLACK line in the intermediate connector (2).
- 3) TRANSPARENT line in the connector on the operator side (3).

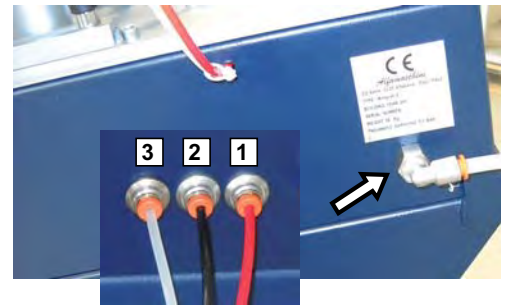

#### Inserting V-nails in the loader

Insert the V-nails as follows:

- (A) Turn the PLV valve (1) lever to the OFF position.
- (B) the V-nail pusher cylinder is opened.
- (C) Insert the stick of V-nails in the magazine (2), ensuring that the sharp part (glued edge) is facing upwards, and that the "V" is positioned as shown in photo (3);
- (D) Turn the PLV valve (1) lever back to the ON position.

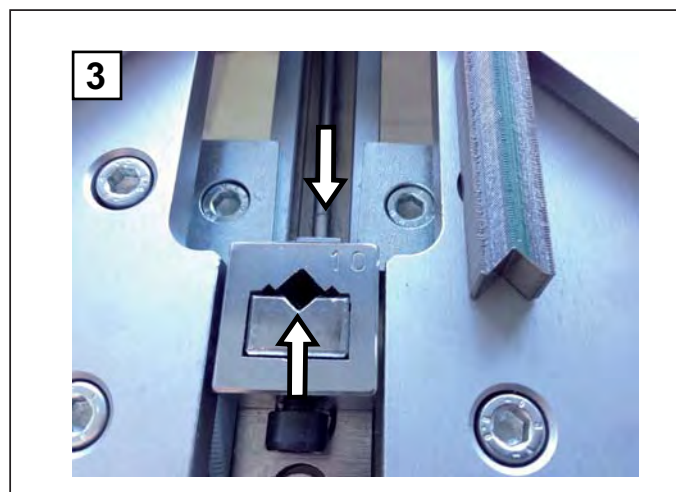
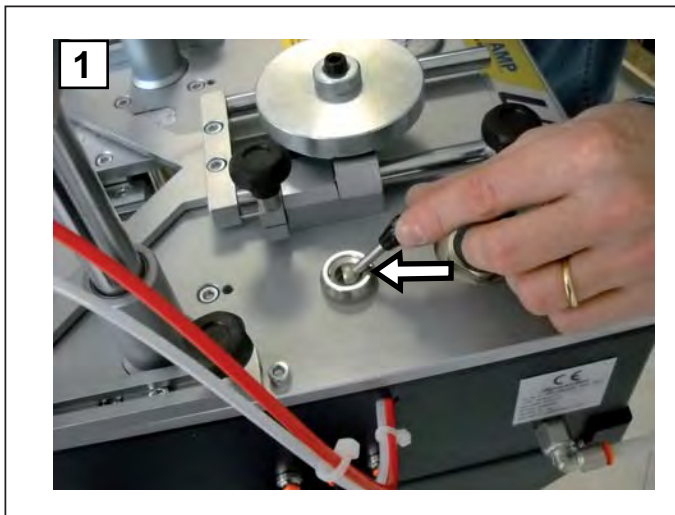

### Changing over the firing head for V-nail changeover.

It is necessary to switch over the nailing head each time a different size V-nail is used.

To replace the head proceed as follows:

1. Loosen the firing head locking screw using a suitable wrench.
2. Lift the head upwards and out.
3. Move the V-nail pusher back using the relative control lever on the right-hand side of the machine's workbench to access the magazine and remove the V-nails inside (if necessary use the special magnetic pencil);
4. Insert the new V-nails (of the required height) in the magazine and move the V-nail pusher forward by activating the control lever.
5. Insert the new head of the height matching the V-nails taking care to check that the number stamped on the head corresponds to the height of the V-nail to be used.

Tighten the firing head locking screw.

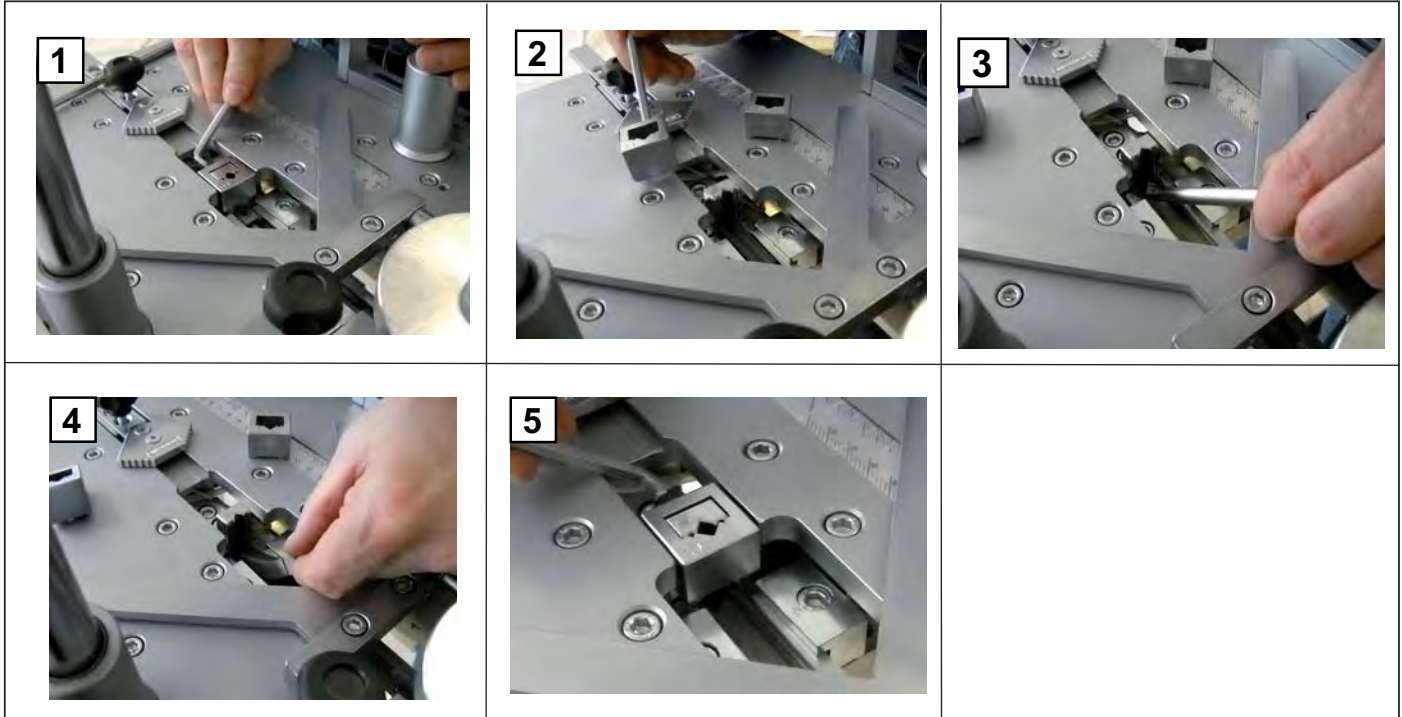

## V-nail firing head alignment



### NOTES

Before proceeding with the operations provided below, disconnect the machine from the compressed air supply and disconnect the tube.

Mechanical alignment of the V-nail firing head is necessary following: loosening caused by work operations, wear on components, jamming during firing, replacement of parts, maintenance. The parts which need to be aligned with one another are: head, L-block support, V-nail magazine and loader.

To perform mechanical alignment, proceed as follows:

1. Undo the socket head screw securing the head to the L-block support and remove the head from the support.
2. Loosen the screws securing the L-block support to the firing unit.
3. Slacken the M5 screws on the two magazine locks.
4. Without forcing it, move the L-block support up to the hammer making sure that the two parts come into contact then tighten the socket head screws.
5. Without forcing it, move the magazine up against the hammer after having loosened the two M5 screws locking the magazine in place.
6. Check that the coupling between the V-nail magazine and hammer is perfect.
7. Tighten the M5 screws which lock the magazine in place.
8. Insert a V-nail in the magazine, move it up against the L-block support to check that the wings of the V-nail are perfectly in line with the guide.
9. Replace the head on the L-block support taking care to ensure it is perfectly resting on it and then lock in place with the relative screw then connect the compressed air supply to the machine and switch on.
10. Insert a stick of V-nails in the magazine and command V-nail firing (with no moulding) to check correct expulsion of the nail.  
The V-nail must run precisely between the L-block support and the head with minimum play and without any resistance.

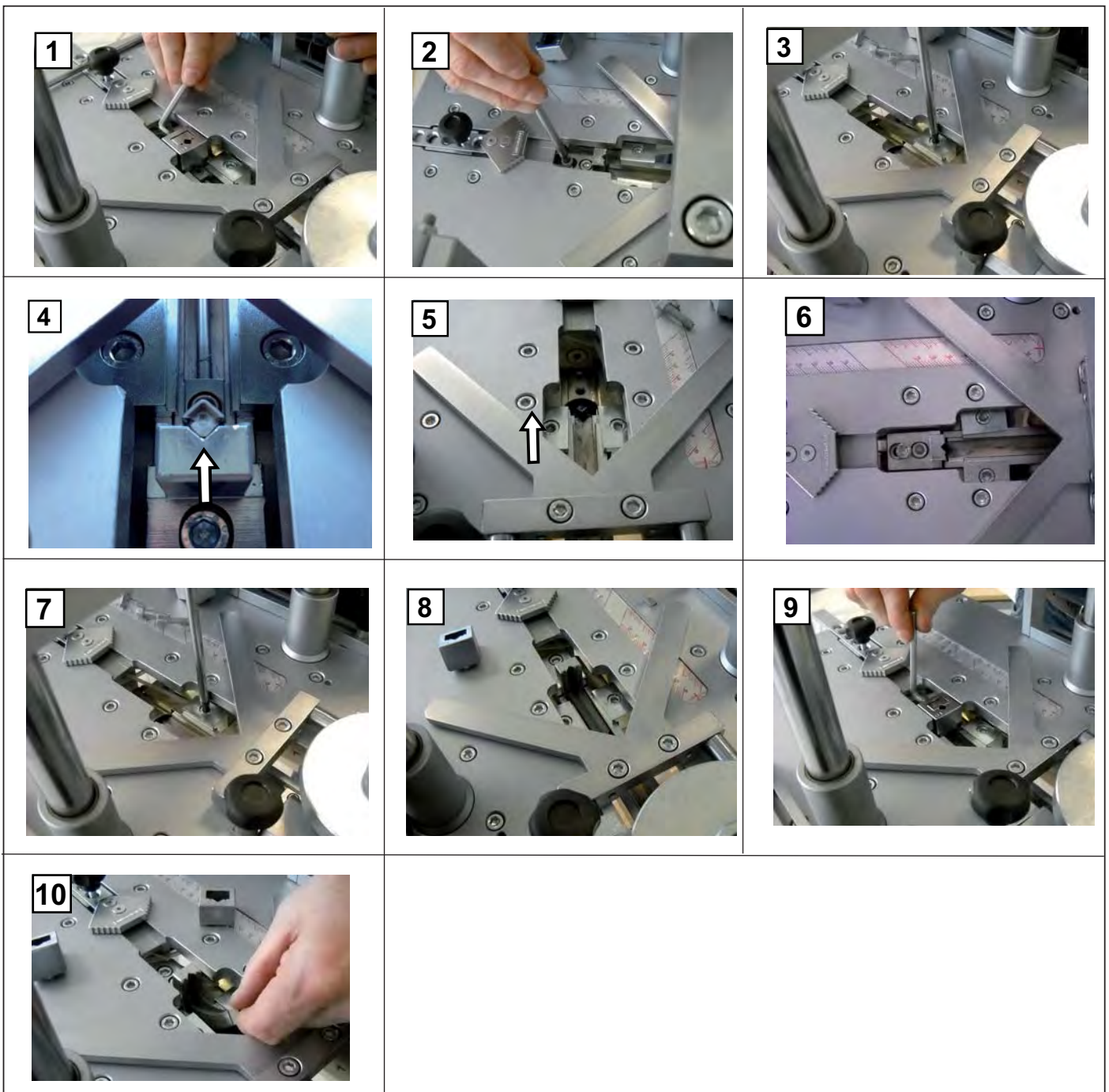

### Adjustment and alignment of the mobile fence

1. Move the transparent fence up to the mobile fence (A). Check that when the fence moves its bisector is aligned with the centre of the V-nail firing head.

If it is not aligned, proceed as follows.

2. Turn the machine over and slacken the screws relative to the blocks (B) which lock the fence guide blocks to the workbench,

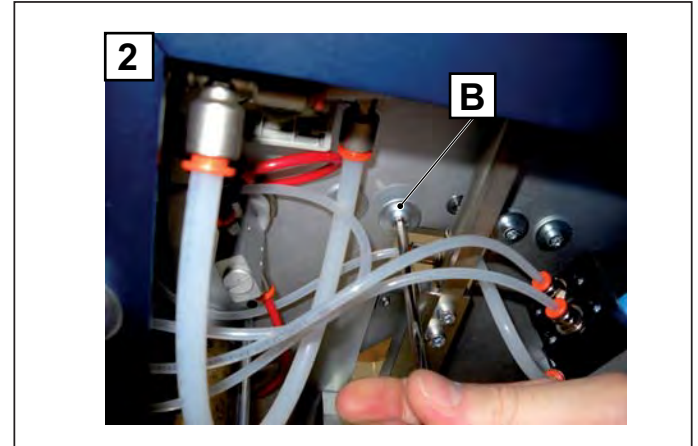
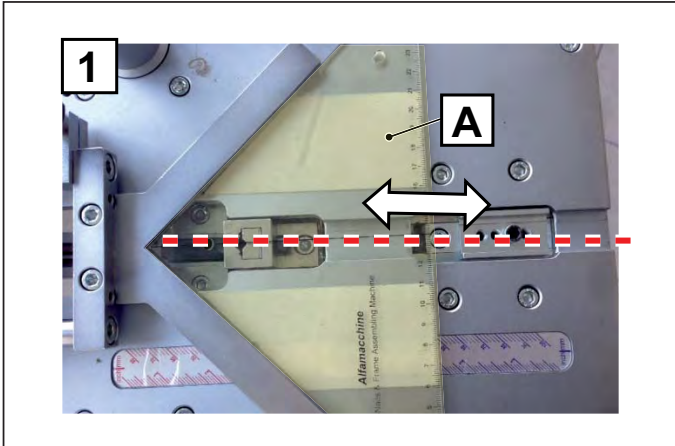

3. Repeat alignment with the transparent fence.

4. Tighten the screws (B).



**Adjustment and alignment of the two-knob fence (optional)**

1. Move the transparent fence up to the mobile fence.



2. Check that when the fence moves its bisector is aligned with the centre of the V-nail firing head.

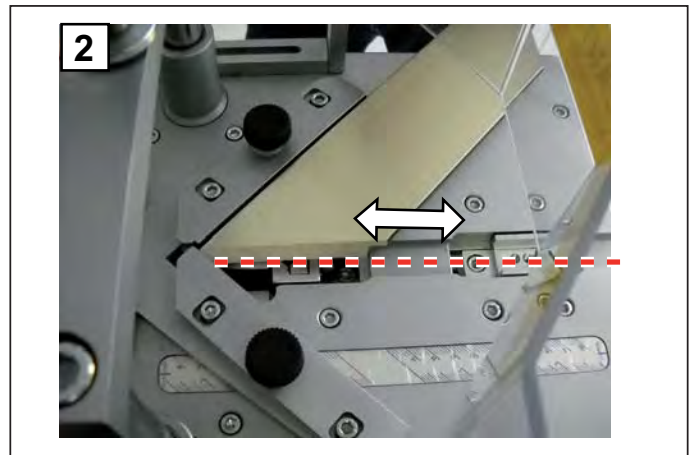

3. To correct the angle of the fences, slacken the 4 screws in the slots, and tighten the screws when adjustment has been completed.

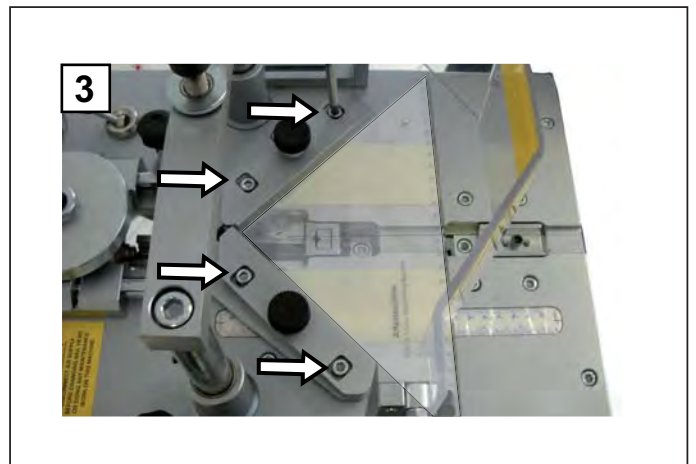

### Fixed fences, optional

1. To vary the contact angle it is necessary to replace the fixed fence with one of the right angle.

The fence for 90° joins (A) (four-sided frame) is part of standard machine equipment.

By installing the optional fence (B) the machine can be used to make 120° joins (six-sided frame).

By installing the optional fence (C) the machine can be used to make 135° joins (eight-sided frame).



**NOTE:** the declared stroke of the machine (80mm) is determined based on the use of the standard 90° fence. If fences with other angles are used (120°, 135°), the stroke is reduced due to the additional encumbrance.

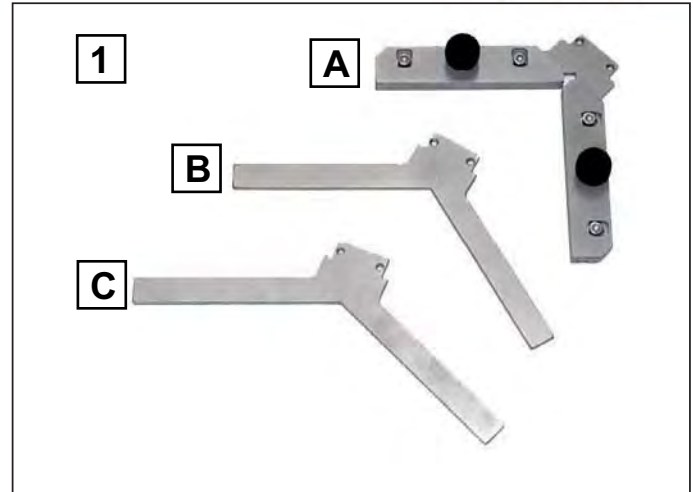

2. To replace the fence unit you must unscrew the 2 socket head screws (D).
3. With screws (D) taken out, the fixed fence can be removed from the support and a new one can be installed in its place and fastened with the same screws (D).

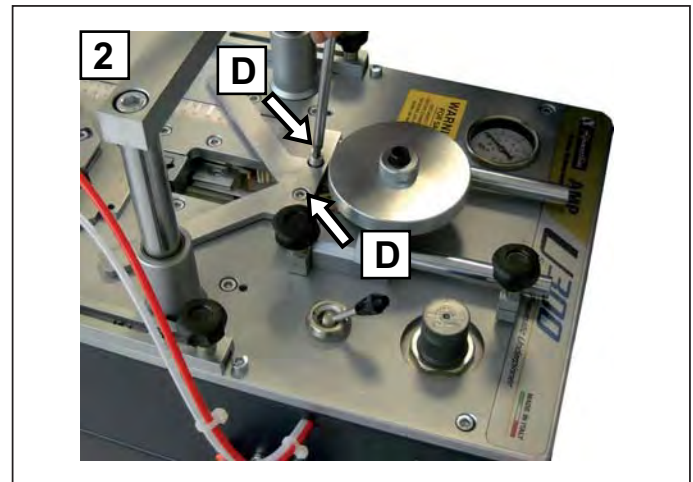

**Adjusting the height and replacing the vertical clamp stopper**

<b>A</b>	Interchangeable rubber stoppers: Soft (blue) Medium (yellow) Hard (black)
<b>B</b>	Single stopper holder
<b>C</b>	Magnetic stopper holder
<b>D</b>	Magnetic support
<b>E</b>	Round magnetic felt stopper.

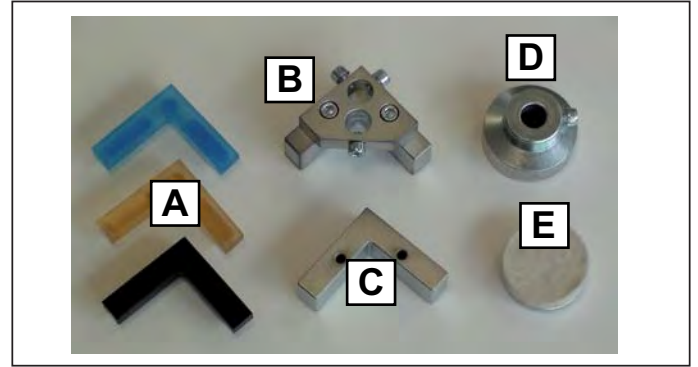

- To adapt the position of the stopper (A) to the thickness of the frame, proceed as follows:
  - Pull the click knob out.
  - Lift or lower the punched rod based on requirements.
  - Release the click knob to block the column.
- To replace the single stopper holder (B, C or D) with the magnetic one, you must unscrew the screw (H) which secures it to the rod and pull it downwards and out.

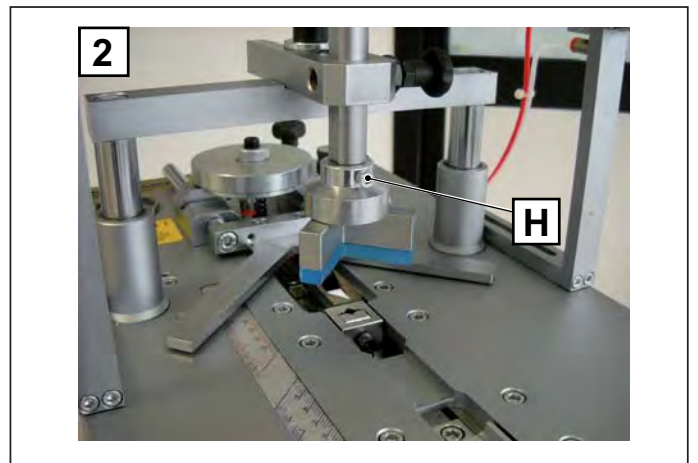
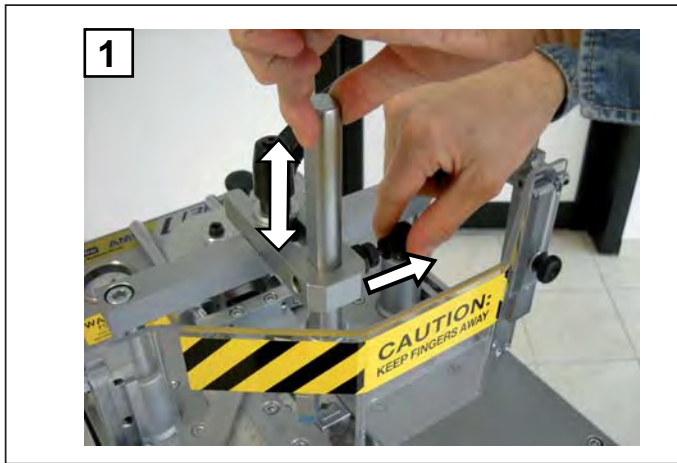

- Fasten the magnetic support (D) or the single stopper holder (B) to the rod clamp by tightening the relative socket head screws (H).
- If you are using the magnetic support (D) attach the magnetic stopper holder (C) or the round felt stopper (E) to the magnet.

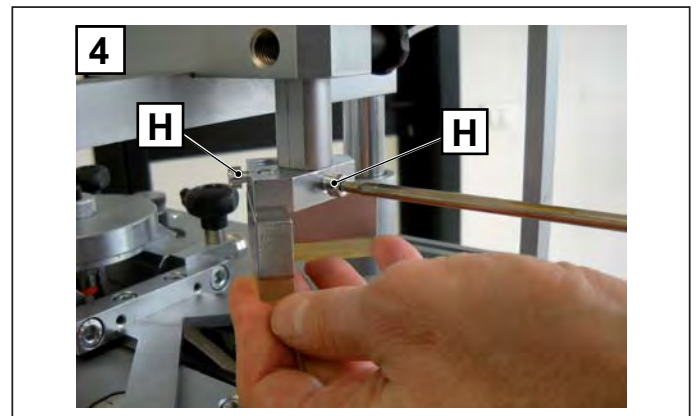

### Installation of interchangeable stoppers

The interchangeable stoppers (A), based on work requirements, may be applied to:

- Corner magnetic stopper holder;
- Single stopper holder

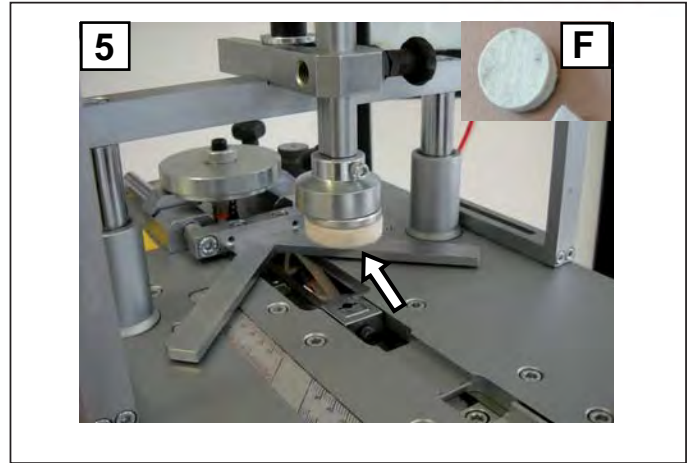

Install the stopper (A) for the required hardness in the stopper holder, positioning it under the slot and manually pressing it in place.

To remove the stopper (A) simply pull it out with your hand by gently taking hold of one of the two sides.

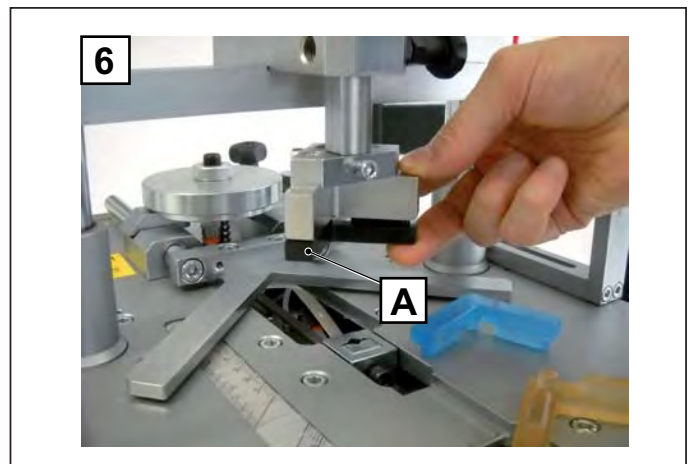

### Adjustment of V-nail insertion positions.

For correct positioning of the mouldings to be joined together, the U300 is fitted with a 90° fence. The fence can be moved forward or backwards so that the V-nails can be inserted in the required position.

To correctly position the fence, proceed as follows:

- slacken the knobs A and B;
- move the fence to the external V-nail insertion position (located at the external vertex of the frame);
- tighten knob A;
- move the fence to the internal V-nail insertion position (located at the internal vertex of the frame);
- tighten knob B;

In this way the operator can easily use the U300 to insert V-nails with maximum precision in two different positions as well as in any intermediate positions.

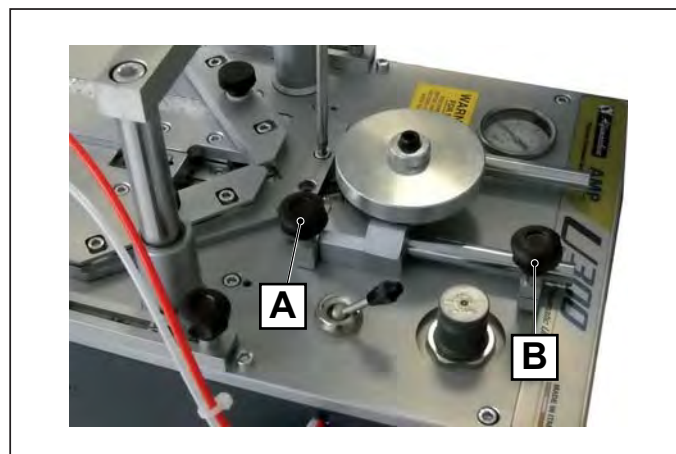

### **Adjusting the pressure of moulding clamping devices**

The procedure for adjusting the pressure of the vertical and front moulding clamping devices is described below.

The work pressure must be suitable for the hardness of the mouldings to be joined.

Adjust the clamping pressure in such a way as to avoid crushing or damaging the surface of the material to be joined, but ensuring that the thrust of the hammer for inserting V-Nails does not cause the moulding itself to rise.

The harder the material to be joined, the greater the pressure that can be applied to the clamping devices is.

To correctly assemble the mouldings, the operator must always check they do not rise when V-nails are being inserted.

An excessively low work pressure may result in the incomplete insertion of the V-nail in the frame.

The work pressure is adjusted by turning the pressure regulator knob (A) located on the working bench.

The work pressure value can be seen on the pressure gauge (B).

To alter the work pressure, proceed as follows:

1. Lift the knob by about 3-4mm.
2. Turn it clockwise to increase the pressure, or anticlockwise to reduce the pressure.
3. Press the knob to lock it back in place.

The following operating pressure values are recommended:

<b>Hardness</b>	<b>Air Pressure</b>
Soft Wood	2 bar / 30 psi 4 bar / 58 psi
Medium/Hard Wood	4 bar / 58 psi 6 bar / 87 psi
Very Hard Wood	6 bar / 87 psi 8 bar / 115 psi

Pressure regulation is carried out manually, so it is possible to use any intermediate value between those indicated.



#### **NOTES**

*Increase the pressure by about 10 - 20% for H15 or overlapping V-Nails. The pressure values indicated in the table are purely indicative and may be subject to variations depending on the types of materials being handled.*

### Adjusting the tilt of the workbench (optional)

Depending on the operator's needs, the workbench can be tilted if the machine is installed on its stand. To carry out adjustments, proceed as follows:

1. Slacken the handle (A) located on one of the legs of the stand, under the working bench.
2. Slowly tilt the working bench to the required position.
3. Re-tighten the handle once the required position has been achieved.

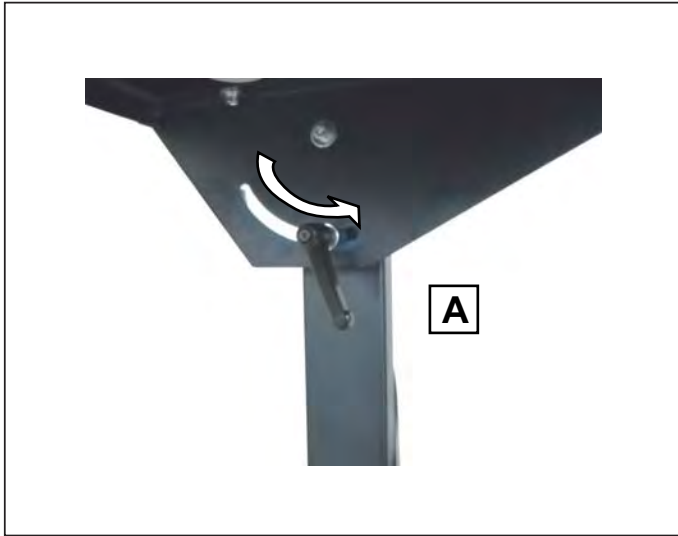

### Adjusting V-Nail positioning

The machine is fitted with a mobile fence unit which is manually moved to reach the V-nail insertion positions. The maximum stroke of the carriage is 80 mm. Various nail insertion points (A) can be defined within this range.

- (A) This picture shows 4 V-nails inserted along the joint between two mouldings.
- (B) Depending on the thickness of the frame, two or more V-Nails can be inserted in the same point.

As well as moulding clamping, a braking system (AFC) guarantees perfect blocking also of the V-nail firing unit during multiple insertion of V-nails in the same position.

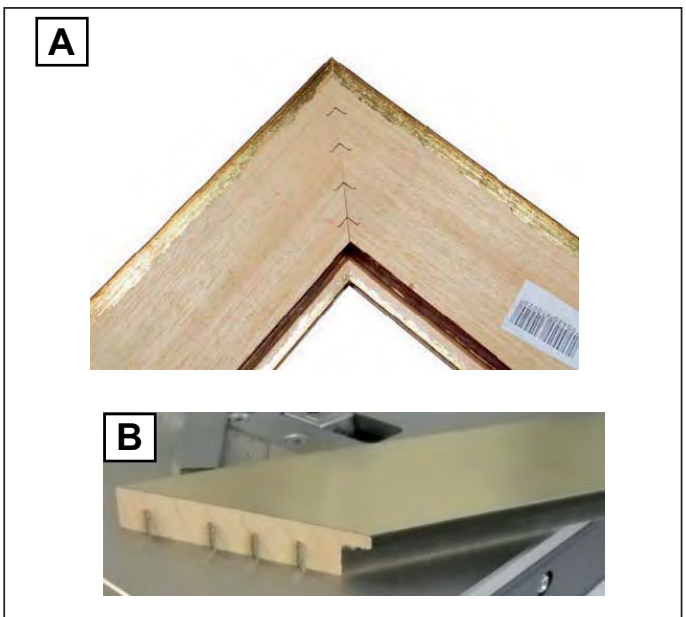

### AFC brake unit adjustment

To adjust the brake unit, proceed as follows:

- Slacken the central ring nut (2)
- Act on the grub screw to determine the braking action (1). Tighten or loosen the grub screw observing the gap created between the clamps and the rods of the mobile fences. This gap must ensure that the fences move backwards and forwards smoothly but are blocked when the pedal is pressed.

**! DANGER - WARNING**  
**WITH THE BRAKE ENABLED THE FENCE MUST BE ABLE TO MOVE SMOOTHLY WHEREAS WITH THE BRAKE ACTIVATED THE FENCE MUST BE BLOCKED.**

- Once adjustment has been completed, tighten the ring nut (2).

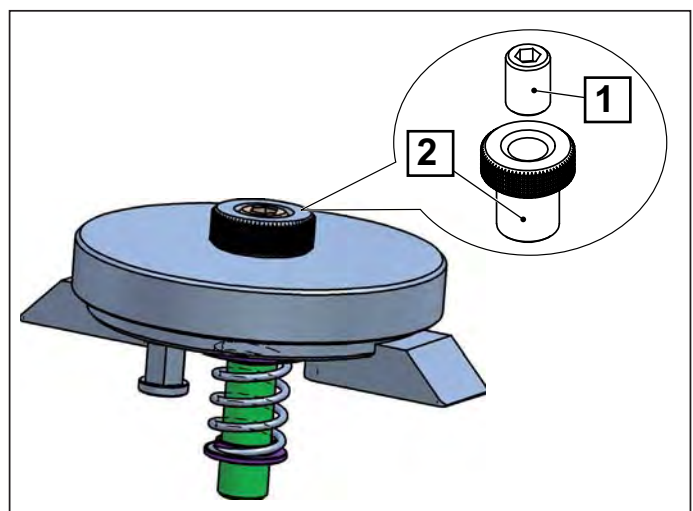

### Rod clamp adjustment

The rod clamp has a series of holes. To adjust the position of the rod clamp, proceed as follows:

- lift the rod and move it backwards and forwards;
- insert the rod on the relative drag screw located in the centre of the guide channel (cursor).

To correctly position the rod clamp, proceed as follows:

- lift the rod from its seat by about 10/15 mm;
- move the rod forward until it reaches the mouldings to be joined;
- lower the punched rod so that the drag screw can be inserted and allow for it to be locked in the new position.



#### NOTES

*In the case of prolonged use with the rod clamp, it is possible to secure it to the cursor using countersunk screws.*



### SUGGESTIONS FOR MAKING PERFECT JOINS

#### 1) V-nail types

In order to ensure that the machine can make top quality joins using a wide variety of materials, different V-nails are available with different degrees of sharpness suitable for use with different hardness values and characteristics of the materials being handled. V-Nails can be divided up into the following categories:

V-nail type	Height mm
H3	3mm (optional)
H5	5mm
H7	7mm
H10	10mm
H12	12mm
H15	15mm

It is advisable to carry out a check on the material in question for selecting the most suitable sharpness.

#### 2) Stapling positions

The following guidelines are designed to help you get the best results in terms of quality joins:

- Avoid inserting V-nails close to the moulding edge. The minimum recommended distance from the outer edge is at least 10mm.
- When creating a joint with just one V-Nail, position the V-Nail on the centre line of the frame.
- If you wish to insert 2 or more V-Nails for each joint, it is advisable to insert the outer V-Nail at 1/3 from the outer edge and the inner V-Nail 1/4 from the inner edge.
- Position the vertical stopper as shown in the figure.

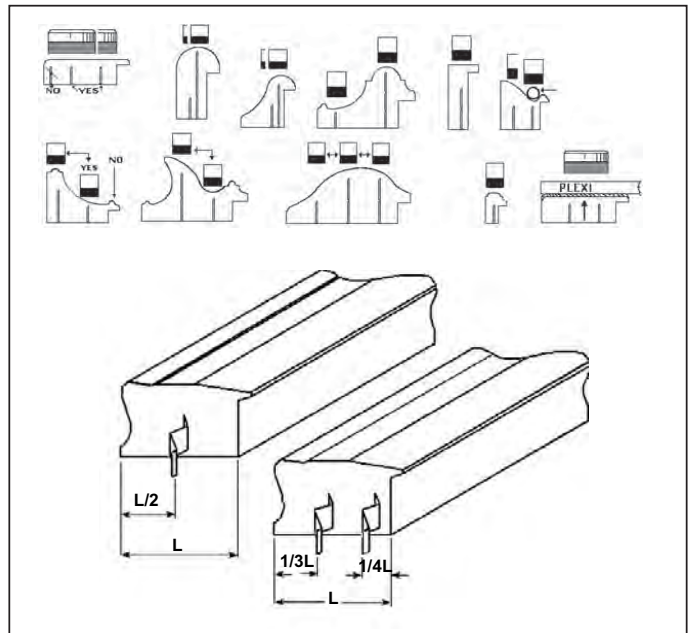

#### 4.5. WORKING CYCLE

**! DANGER – CAUTION**  
During normal use, the machine must only process the products/materials indicated in this manual.

Safety measures and the indications on residual risks must always be observed during machine operation. Insert the compressed air supply connector directly into the machine.

Check that the V-nail magazine is full and that the head corresponds to the height of the V-nails and is correctly installed.



Connect the pedal and make sure the various pneumatic lines have been inserted in the correct sequence.

- 1) RED line in the connector on the outer side (1).
- 2) BLACK line in the intermediate connector (2).
- 3) TRANSPARENT line in the connector on the operator side (3).

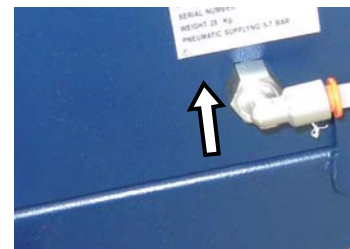
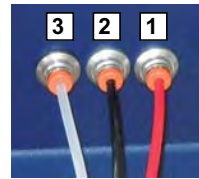

Make all the necessary regulations based on the dimensions of the mouldings and then:

- adjusting the rod clamp and mobile fence.
- vertical stopper adjustment.

Whenever the two-knob fence is being used, insert the first moulding on the right-hand side of the fence and then bring the left-hand moulding (error condition).

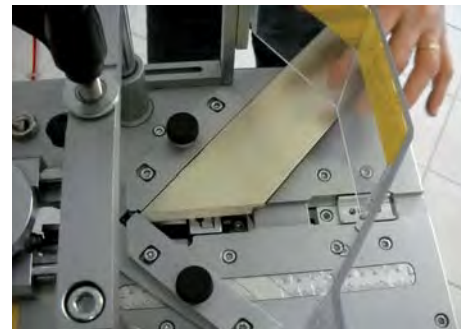

The pedal has three positions:

- Position 1 - Stand-by
  - Position 2 - Pressed halfway down to automatically activate horizontal and vertical clamping.
  - Position 3 - Pressed all the way down commands the hammer for V-nail insertion.
- Release the pedal for the new V-nailing position and repeat the operation.



1. Taking care over the hazardous areas, use your hands to accompany the movement of the fences and the mouldings up to the desired V-nail insertion position.
2. Position the rod clamp and then press the pedal halfway down (2) to activate vertical and horizontal clamping.
3. Press the pedal (3) all the way down to insert the V-nail.
4. Lift the pedal to the halfway point (2) and then press all the way down again (3) to insert the other V-nails in the same place.
5. Completely lift the pedal to release the moulding and reposition the fences as required.
6. Repeat the operation



#### 4.5.1. CYCLE STOP

**DANGER - WARNING****THE MACHINE MUST BE SWITCHED OFF AFTER USE.****THE COMPRESSED AIR LINE MUST BE DISCONNECTED.****PNEUMATIC ACTUATORS MAY HOLD ACCUMULATED ENERGY WHICH MUST BE DISCHARGED OF PRESSURE TO AVOID HAZARDOUS UNEXPECTED MOVEMENTS.**

If there is a filter unit, turn the knob to discharge the machine's compressed air circuit and then disconnect the compressed air line.

## 5. MAINTENANCE, TROUBLESHOOTING, AND CLEANING

### 5.1. MAINTENANCE TECHNICIAN REQUIREMENTS

The term “maintenance” does not just cover periodical controls of normal machine operation, but also the analysis and consequent rectification of any of those problems which for any reason stop the machine from working properly or not at all.

Specifically, personnel appointed to perform the servicing, cleaning, replacing of parts and troubleshooting, must work in compliance with the following aims:

1. limit the deterioration of wear parts.
2. reduce accidents to the absolute minimum.
3. reduce costs arising from faults.
4. limit the number and duration of interventions.

5. work in collaboration with the line operators to improve the efficiency of the plant.

### 5.2. WORK STATIONS AND MAINTENANCE TECHNICIAN DUTIES

The maintenance technician duties are:

- to perform tooling operations and adjust mobile parts on the machine,
- to calibrate, adjust and clean internal machine parts,
- to clean the inside of the machine (disassembling parts if necessary), carry out maintenance, lubrication, assistance operations, troubleshooting and the replacements of worn or damaged parts or structural elements.

The work zones that may present risks for the machine’s maintenance technician are the following:

- the area relative to tooling, calibration, adjustment, lubrication, troubleshooting, worn and broken part replacement operations, as indicated in this instruction manual,
- the areas in and around the machine during the movement of mobile parts,
- the areas around piping;
- the areas around the fixed guards.

Schematic indications of the danger zones for machine maintenance technicians:

- A. area under the stopper
- B. area in front of the rod clamp
- C. area around the rod clamp cursor if removed

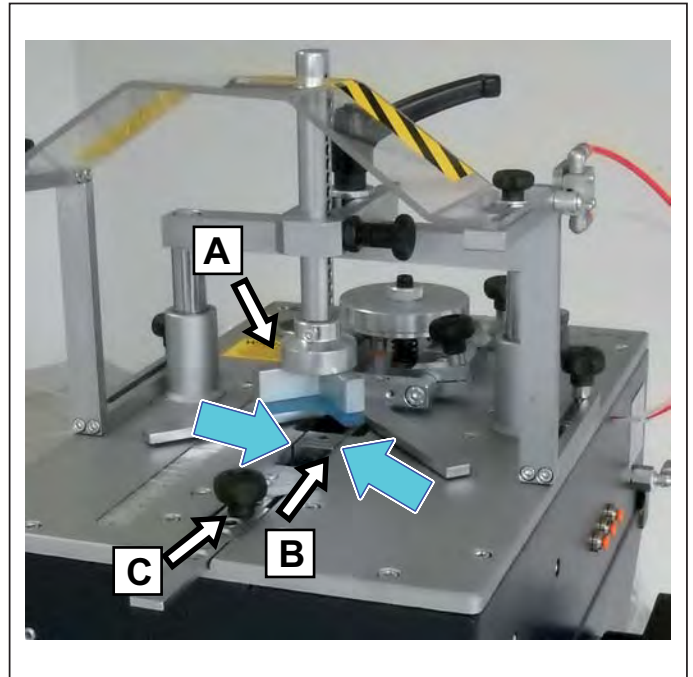

### 5.3. MAINTENANCE PRESCRIPTIONS



#### DANGER - WARNING

**ALL THE MAINTENANCE, CLEANING AND PARTS REPLACEMENT MUST BE CARRIED OUT SOLELY AND EXCLUSIVELY WITH THE MACHINE DISCONNECTED FROM ALL POWER SUPPLIES.**

It is prohibited to perform any maintenance work on parts that are in motion.

#### 5.4. GENERAL WARNINGS



##### DANGER - WARNING

**BEFORE PERFORMING ANY MAINTENANCE, CLEANING, REPLACEMENT OF PARTS AND TROUBLESHOOTING, PAY THE UTMOST ATTENTION TO THE DECALS AFFIXED TO THE MACHINE.  
DURING ALL ACTIVITIES DO NOT TAMPER WITH OR DEACTIVATE ANY OF THE SAFETY DEVICES FOR ANY REASON, EITHER TO CREATE BYPASSES OR TO USE THEM FOR PURPOSES OTHER THAN THEIR INTENDED USE AS PRESCRIBED BY THE MANUFACTURER.**

After performing any of the above tasks on the machine, reset and reactivate all the safety devices.

Do not tamper with or deliberately damage the protective screens nor remove or conceal the warning notices. In the event of deterioration or illegibility of the safety decals immediately order replacements from the equipment supplier.



##### DANGER - WARNING

**BEFORE PROCEEDING WITH MAINTENANCE, CLEANING AND/OR THE REPLACEMENT OF PARTS, ALWAYS PUT UP A SIGN WHICH IS CLEARLY VISIBLE INDICATING THAT MAINTENANCE OPERATIONS ARE UNDERWAY AND THAT THE MACHINE CAN ONLY BE RESTARTED AFTER HAVING DULY ASCERTAINED THAT ALL OPERATIONS HAVE BEEN COMPLETED AND ALL SAFETY GUARDS HAVE BEEN REPLACED.**

#### 5.5. ISOLATION FROM EXTERNAL ENERGY SOURCES

During maintenance, cleaning and replacement of parts, the machine must not be used and no commands must be transmitted.

Before performing any maintenance, lubrication, cleaning and replacement of parts etc. external energy supplies must be disconnected.

All disconnecting devices must be padlocked in the "0" (OFF) position.

Turn the knob to discharge residue pressure from the pneumatic system and disconnect the compressed air line.

#### 5.6. ROUTINE MAINTENANCE

Personnel responsible for carrying out the operations described in this chapter must have read, understood and consequently observe all the safety prescriptions, in particular:

1. waiting for the stopping times, before inserting limbs or parts of the body into the machine danger areas,
2. the adequate use of personal protective devices and safety accessories needed to perform cleaning operations inside the machine's danger areas,
3. It is prohibited to perform any repair or adjustment work on moving parts,
4. before performing any maintenance, cleaning and replacement of parts, the machine must be isolated from all energy supplies.

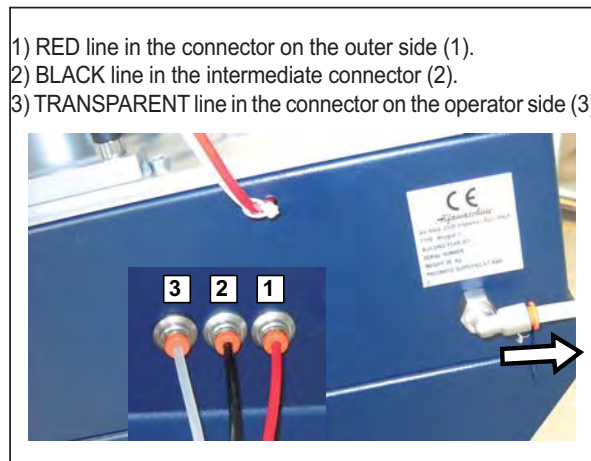

Furthermore, all general rules must be observed to keep the machine in perfect working order:

1. keep the machine clean and tidy,
2. avoid all damage,
3. avoid a situation wherein make-shift or urgent repairs become commonplace,
4. do not perform work on the machine which produces swarf; for example, should it be necessary to drill holes, carefully check that no residues end up in machine parts,
5. for disposal of worn or replaced materials, observe the relative legislation in force.

**5.7. TASKS THAT CAN BE PERFORMED BY THE OPERATOR**

A list of all the periodical checks/inspections, adjustment and control operations and ROUTINE MAINTENANCE operations which can be carried out by the machine operator is provided below.

The position of the machine components is shown in the layouts provided as an appendix to this manual.

FREQUENCY	CHECK	METHODS AND RESULTS
Before each shift	Working area: <ul style="list-style-type: none"> <li>• must be clean and free from dust</li> </ul>	<p>The work station and all the parts outside the machine must be cleaned and all dust and objects must be removed which could impede correct operation and/or compromise the machine's original safety conditions.</p> <p>Remove all shavings from the machine with a jet of compressed air and lint-free cloths.</p> <p>For any type of intervention or to replace parts, call in the maintenance service.</p>
Before each shift	Check operation: <ul style="list-style-type: none"> <li>• of the emergency stop device;</li> <li>• of the command/control devices relative to safety;</li> </ul>	<p>At the first sign of problems it is necessary to remedy the situation by implementing an inspection procedure to check the correct mechanical operation of the devices.</p> <p>For any type of intervention or to replace parts, call in the maintenance service. Parts must always be replaced using original spare parts or at least parts which provide equivalent quality and safety .</p>
Before each shift	Visual inspection of the condition: <ul style="list-style-type: none"> <li>• of fixed guards</li> </ul>	<p>All fixed guards must perform the function they were designed for. Check their integrity, both internally and externally and make sure there are no signs of wear or breakage.</p> <p>For any type of intervention or to replace parts, call in the maintenance service.</p> <p>During operation it is possible that V-nails come out of the magazine and remain in circulation near the nailing head. Remove them using the magnetic pen provided</p>
When necessary	Visual inspection: <ul style="list-style-type: none"> <li>• blocked V-nails</li> </ul>	 <p>If they become unreadable new ones must be requested from the manufacturer or they must be replaced by the user with others carrying the exact same information.</p>
At least once a week	Visual inspection of the condition: <ul style="list-style-type: none"> <li>• of all dataplates</li> </ul>	

Parts must always be replaced using original spare parts or at least parts which provide equivalent quality and safety . The instructions concerning the replacement are not given in this manual and they must therefore be explicitly requested from the machine manufacturer, which reserves the responsibility for the replacement interventions.

### 5.8. TASKS THAT CAN BE PERFORMED ONLY BY MAINTENANCE TECHNICIANS

The ROUTINE MAINTENANCE operations which must be performed by a maintenance technician are indicated below.

The instructions concerning the replacement are not given in this manual and they must therefore be explicitly requested from the machine manufacturer, which reserves the responsibility for the replacement interventions.

FREQUENCY	CHECK	METHODS AND RESULTS
Every 1,000,000 V-nails inserted	Check / replace: • gaskets and hammer	Proceed to dismantle the hammer to replace the gaskets only or the whole piston as follows:

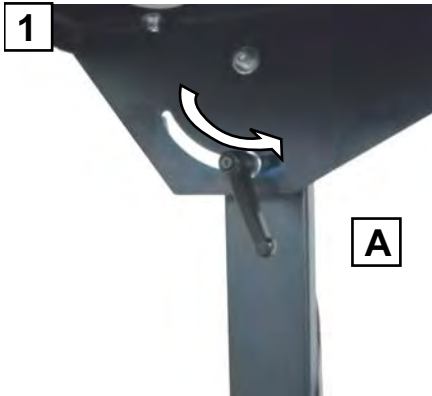

- Slacken the locking handle on the stand to tilt the working bench backwards.  
Disconnect the air supply from the machine.



- Disconnect the 2 pipes connected to the cylinder.  
Remove the 4 socket head screws which secure the pneumatic cylinder to the head.

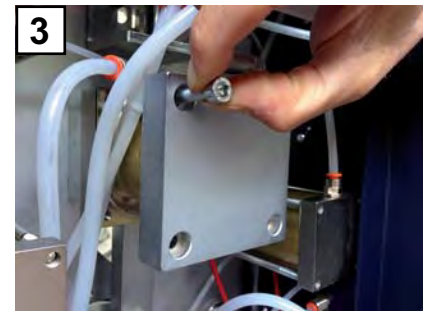

- Remove the pneumatic cylinder and extract the hammer if it is still inside it.  
Remove all traces of dirt, clean with degreaser, check for wear, grease all the internal surface.



- Replace the external head seal with the aid of a screwdriver.  
Clean the seal seat thoroughly and grease.

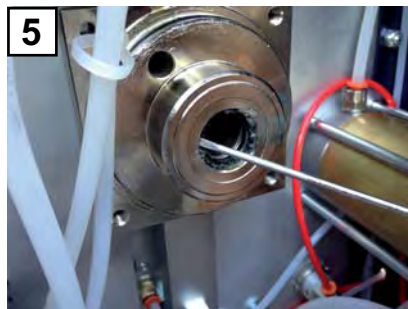

- Replace the lip seal inside the head with the aid of a screwdriver.  
Clean the seat and the bush hole thoroughly and grease.



- Remove the seals from the hammer, clean well and grease, check for wear or the presence of chips.  
Install the new seals making sure the lip seals are placed the right way round.

7



7. If the hammer is worn out or chipped, proceed to replace the whole piston. The raised ends of the hammer must have marked edges to ensure correct insertion of the V-nail.

8

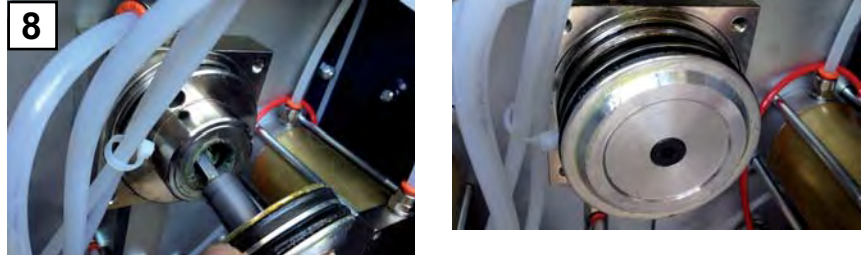

8. Grease the hammer piston and the seals well then insert it in the special hole taking care not to pinch the lip seal. If insertion proves difficult, try removing the L-block support, head and V-nail loader.

9

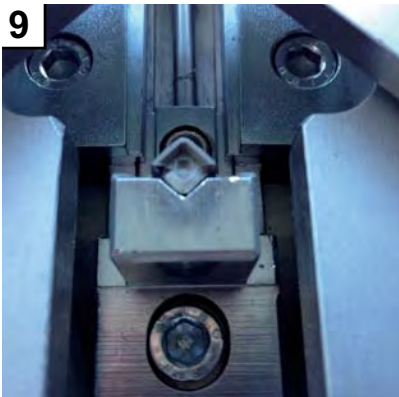

9. Note: position the hammer so that the high part of the piston has the two raised edges pointing towards the magazine.

10

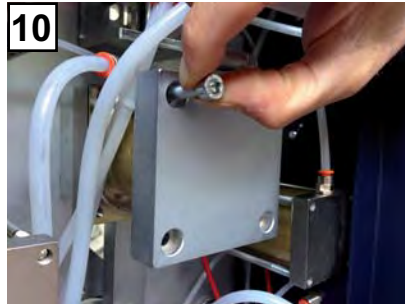

10. Replace the cylinder and move it well up against the head. Secure in place with the 4 screws and reconnect the air lines.

At the end of the operation check alignment of the V-nail firing head: magazine and head:

reconnect the air supply to the machine and activate the hammer several times to make sure it moves correctly and that there are no mechanical hindrances.

Insert the loader with the V-nails and fire several times to make sure the V-nails are correctly fired from the head.

FREQUENCY	CHECK	METHODS AND RESULTS
Every 5,000,000 V-nails inserted	Check / replace the "L" support block	Proceed with disassembly by following the instructions in the heading MECHANICAL ADJUSTMENTS / MAINTENANCE
At least once a month		All the parts inside the casings and in the machine housings where the motors are installed, must be kept clean and dry. Use suitable and normally available tools and equipment (e.g. vacuum cleaners and dry brushes to remove dust and absorbent cloths for removing moisture) to keep said areas of the machine in a suitable operating condition.
At least once a month	<b>Check the affectiveness:</b> <ul style="list-style-type: none"> <li>of the mechanical connections</li> </ul>	Use suitable tools and equipment to check the tightness of terminals, screws, nuts, bolts and connections in general on both the equipment and the machine.
At least once every 3 months	<b>Check reliability and operation:</b> <ul style="list-style-type: none"> <li>of fixed guards</li> <li>of the safety devices.</li> </ul>	<b>The necessary inspections concern:</b> <ul style="list-style-type: none"> <li>loss or damage to any part of the safeguards, especially if this entails a reduction in the safety function it is designed to perform, for example a reduction in resistance to impact caused by scratches/damage to Plexiglas panels.</li> <li>replacement of wear parts;</li> <li>correct operation of interlocks;</li> <li>deterioration of joints or fixing points;</li> <li>deterioration due to corrosion, temperature variations or chemical effects;</li> <li>satisfactory operation and lubrication of moving parts, if necessary;</li> <li>modification of safety distances and size of openings;</li> <li>deterioration of the acoustic performance, if applicable.</li> </ul> <p>Replacement must be carried out when one of the components indicated displays anomalous wear and at the first sign of cracking, erosion or breakage. Parts must always be replaced using original spare parts or at least parts which provide equivalent quality and safety . Contact the manufacturer directly.</p>

Parts must always be replaced using original spare parts or at least parts which provide equivalent quality and safety .  
THE INSTRUCTIONS CONCERNING THE REPLACEMENT ARE NOT GIVEN IN THIS MANUAL and they must therefore be explicitly requested from the machine manufacturer, which reserves the RESPONSIBILITY FOR THE REPLACEMENT INTERVENTIONS.

## 5.9. CLEANING



### **DANGER – CAUTION**

***It is prohibited to manually clean, oil or grease moving machine parts and elements unless this is strictly necessary for some specific technical requirement. If this is the case all suitable measures must be taken to prevent hazards.***

***Workers must be informed by means of clearly visible warning signs.***

***Cleaning operations which can be performed by maintenance technicians are indicated below.***

Normally, some cleaning operations can be performed by the machine runner; i.e., in the case of normal operations on the outside of the machine that call for the use of simple personal protective equipment..

Cleaning operations of the internal parts of the machine must be performed by the maintenance service.

To avoid inadvertent untimely and hazardous activation of the machine or unwanted and inadvertent modifications of any kind, cleaning operations should be carried out by the same personnel who usually work on the machinery rather than personnel from a cleaning company who may not observe all the recommendations indicated herein.

All cleaning operations must be carried out only after the machine has been cut off from external power supplies and all accumulated energy has been discharged.



### **DANGER – CAUTION**

***Never use petrol, solvents or other inflammable and/or corrosive fluids to clean the machine or its components. Use exclusively commercial, approved non-flammable and non toxic solvents.***

Comply with the methods of use and use all the necessary personal protective equipment specified by the supplier of such substances.

The machine, its on-board components must never be washed with water, especially not in the form of jets of any type or intensity; i.e. it must not be washed using buckets, hoses, or even sponges.

For the identification of the components mentioned and details on their position, refer to the “mechanical components” layout and the layout provided with the machine.

Fixed guards must be removed in order to gain access to some of the parts requiring lubrication.

Fixed guards are identified by the following sign:



Once all cleaning operations have been completed, all the fixed guards must be refitted and secured in place.



FREQUENCY	PERSONALE	ZONE - METHODS
When necessary	Also the operator	THE WORKING BENCH AND THE HEAD must be kept clean from all residues of glues used to join the frames. Do not use water. Use a petroleum based cleaning product.
When necessary	Also the operator	THE V-NAIL MAGAZINE AND GUIDE must be kept clean from any residues and dust. Do not use water. Use a petroleum based cleaning product.
At least once every week	Also the operator	<ul style="list-style-type: none"> <li>• THE WORKPLACE AND THE CONTROL STATION must be kept clean and tidy. Remove all dust and dirt. An untidy workplace increases the risk of accidents. During cleaning operations, always use a dust mask and any other PPE prescribed for the type of operation being carried out and depending on the substances used for cleaning. Comply with the methods of use and use all the necessary PERSONAL PROTECTIVE EQUIPMENT SPECIFIED BY THE SUPPLIER OF SUCH SUBSTANCES.</li> <li>• Avoid the use of rubbing alcohol, benzene, solvents or any other type of detergent on non-metal parts which, when necessary can be cleaned using a neutral, non-foaming, water-based detergent ONLY . If necessary, metal parts can be cleaned using a lint-free cloth dampened slightly with rubbing alcohol, taking great care however not to come into contact with any adjacent or nearby plastic materials. Never use abrasive products, coloured substances, metal scourers, wire brushes, scrapers, etc.</li> <li>• Comply with the methods of use and use all the necessary PERSONAL PROTECTIVE EQUIPMENT SPECIFIED BY THE SUPPLIER OF SUCH SUBSTANCES.</li> </ul>
At least once every six months	Maintenance technician	<ul style="list-style-type: none"> <li>• Remove all rust marks that may have formed on unpainted surfaces during transport or storage. For this operation use a specific commercial antirust agent.</li> <li>• Comply with the methods of use and use all the necessary personal protective equipment specified by the supplier of such substances.</li> <li>• Remove the double-action purifying filter (centrifugal for capturing large particles of impurities and condensate and filtering for the smaller solid particles suspended in the air) located in the compressed air supply hook-up zone.</li> <li>• CONDENSATE IS DRAINED by means of the special valve (A) on the bottom of the collection cup (B). The cups can also be taken out for cleaning.</li> <li>• CONDENSATE MUST ALWAYS BE drained before it reaches the level of the filtering elements or the filter separators.</li> <li>• When cleaning, do not use synthetic solvent-based degreasing substances.</li> <li>• Once the filters are clean they can be refitted in the places from which they were removed and the grills must be refitted and fastened in place. Wear a dust mask during cleaning procedures.</li> </ul>

## 5.10. LUBRICATION

During lubrication operations:

1. Avoid bringing oil and/or grease into contact with the skin.
2. During oil and/or grease changes use protective gloves.

Both spent and fresh lubricants are highly polluting: for disposal of lubricants consult your lubricant dealer or contact a specific toxic waste disposal company.

All lubrication operations must be performed:

1. after first cutting off all external energy supplies,
2. strictly observing the safety indications given in the "safety datasheets" provided with each individual lubrication product used.

The lubrication operations which must be performed by maintenance technicians are indicated below.

To obtain high performance and faultless operation, it is important to lubricate moving parts of the machine on a regular basis.

The position of machine components which need lubricating is shown in the layout provided as an appendix to this manual.

For the disposal of spent oil and grease, observe the relative legislation in force.

Do not disperse spent oil in the environment. Consign it to specifically authorised collection centres.



### NOTES

*Fixed guards must be removed in order to gain access to some of the parts requiring lubrication.*

*Fixed guards are identified by the following sign:*



Once lubrication operations have been completed, all the fixed guards must be refitted and secured in place.



### NOTES

- We recommend the use of castrol magna GC32 oil or equivalent; no silicone oil
- Lubrication with inappropriate products may damage the seals on the pneumatic devices.

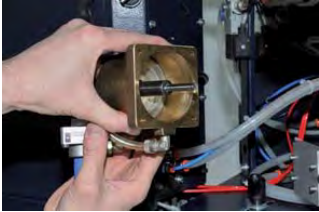
FREQUENCY	LUBRICATION	METHODS AND RESULTS
At least once every six months	Maintenance technician	<p>Lubricate the hammer piston by following the instructions provided in the heading ROUTINE MAINTENANCE.</p>   <p>Lubricate the carriage guides located under the working bench.</p>
Every 200 service hours	Hammer piston	<p>Automatic lubrication of the pneumatic actuators. Make sure there is oil in the reservoir of the filter unit.</p>

## 6. TROUBLESHOOTING AND RELEASE OF MOVING PARTS

If any of the moving parts becomes jammed, in order to release it in conditions of safety the machine operator must first stop the machine and then inform the persons in charge of maintenance, if he has not been authorised to release jammed parts beforehand. The following section describes operations for troubleshooting and releasing moving parts that can be performed by maintenance technicians.

Before performing any work or investigations:

1. Install a sign indicating that maintenance is in progress on the machine
2. Make sure that the upline and downline connected machines do not constitute a source of danger or an impediment to the maintenance work; switch off said machines using the designated procedures.
3. Before restarting the machine, make sure there are no personnel still performing cleaning and /or maintenance operations on it.
4. For mechanical repair work, always seek the assistance of the manufacturer.
5. Always consult the machine manufacture in accordance with the methods specified on the initial pages of this manual.
6. Do not zero/reset the safety devices automatically by means of an external sequence without first checking and identifying the cause of the stoppage.

By observing any types of information that the machine control system provides, machine faults can be identified and interpreted. All information devices (visual, audible) aimed at avoiding potential ergonomic hazards, with the relative explanations and the type of information the operator/s will receive are described in chapters 3 and 4.

Depending on the type of information, action must be taken to eliminate the cause that led to/generated the visual or audible alarm signal.

The PROBLEMS OR FAULTS which could lead to a MACHINE STOPPAGE are:

PROBLEM / FAULT	POTENTIAL CAUSE(S)	METHODS AND ANCILLARY NOTES
<b>When the pedal is fully pressed and then the button is pressed, the V-nails are not fired properly.</b>	Insufficient operating pressure	<ul style="list-style-type: none"> <li>- Check that the minimum pressure value for the system is over 6 Bar.</li> <li>- Check that the operating pressure value is between 4 / 7 Bar.</li> <li>- Check that the pressure value indicated on the gauge is over 2 bar, value based on the hardness of the material being joined.</li> </ul>
	V-nails badly positioned in the loader.	<ul style="list-style-type: none"> <li>- Check that the sharpened part (edge with glue) is pointing up.</li> <li>- Check the direction of the V-nails</li> <li>- Check that the top of the "V" of the nails is pointing towards the back of the machine or in the direction of the fences.</li> <li>- Check that the V-nails show no signs of faulty gluing, uneven profiles, etc., replace if necessary.</li> </ul>
	V-nail guide channel (L-block support) blocked or worn.	Check that the V-nail guide channel (L-block support) is not dirty or clogged. Clean if necessary.
	Insufficient thrust from the V-nails pusher	Check that the pressure of the reduction valve which supplies the V-nail pusher cylinder is at least 2 Bar. If necessary increase by 10%.
	Faulty V-nails	- Replace the V-nails
	Insufficient air pressure	Check that the air pressure from the compressor is at least 6 Bar.
	V-nail magazine open	Close the magazine by acting on the relative lever valve (ON position) <ul style="list-style-type: none"> <li>- Replace the pedal valve.</li> </ul>
	Faulty valves	- Replace the control valves.
<b>Pressing the button more than once, operation starts out correctly but becomes irregular.</b>	Valves clogged by excess oil or condensate.	Remove any excess oil or condensate from the valves by disconnecting the command lines one at a time and bleeding them of air.
	Faulty valves	Replace the valves if necessary. <ul style="list-style-type: none"> <li>- Replace the pedal valve.</li> <li>- Replace the control valves.</li> </ul>

PROBLEM / FAULT	POTENTIAL CAUSE(S)	METHODS AND ANCILLARY NOTES
<p>When the pedal is pressed, the machine works properly, but when the pedal is released, there is a slight delay in the repositioning of the columns and/or hammer.</p>	<p>Faulty or clogged valves</p>	<ul style="list-style-type: none"> <li>- Remove oil and/or condensate</li> <li>- Replace the pedal valve.</li> <li>- Replace the faulty control valves</li> </ul>
<p>When wishing to insert more than one V-nail in the same point, they do not overlap in height or when inserted they end up in a slanting position.</p>	<p>Unsuitable V-nails</p>	<p>Change the V-nails for suitable ones</p>
	<p>Incorrect frame clamping (the frame moves around during V-nail insertion)</p>	<ul style="list-style-type: none"> <li>- Check and if necessary correct the position of the vertical stopper and the rod clamp.</li> <li>- Increase the pressure by acting on the pressure reducer</li> </ul>
	<p>Worn hammer</p>	<ul style="list-style-type: none"> <li>- Replace the stopper with a more suitable one</li> <li>- Replace the hammer</li> </ul>
	<p>Obstructed hammer</p>	<p>Clean the top part of the hammer to remove any product which may have clogged the upper profile</p>
	<p>The V-nail firing unit is not at the same level as the working bench</p>	<p>Adjust the V-nail firing unit so that it is at the same level as the working bench</p>
<p>Working in a horizontal position, the carriage tends to go towards the upper stopper and when the lever is pulled towards the bottom stopper it is very difficult.</p>	<p>Balancing cylinder powered</p>	<p>Act on the pressure reducer and set the pressure at 0 bar</p>
	<p>Machine moving parts are not well lubricated.</p>	<p>Check for and remove any jamming of moving parts and/or perform lubrication if required.</p>

## 7. REINSTALLATION AND REUSE

 **CAUTION - DANGER**  
MOVING AND REINSTALLING THE MACHINE IN A DIFFERENT LOCATION ARE HIGHLY DELICATE OPERATIONS WHICH CALL FOR SIGNIFICANT EXPERIENCE. CONSEQUENTLY TO ENSURE THAT THE OPERATIONS ARE CARRIED OUT WITHOUT ANY RISKS FOR PERSONNEL OR THE MACHINE, THESE OPERATIONS MUST BE CARRIED OUT SOLELY AND EXCLUSIVELY BY PERSONNEL APPOINTED DIRECTLY BY THE MACHINE MANUFACTURER OR AUTHORISED BY THE SAME.

## 8. EXTINGUISHING MEDIA

The indications on extinguishing media are of fundamental importance as any operations/interventions which are not carried out in compliance with the indications provided below or are not foreseen, may damage the machine, its internal components, the power supply system, the product being handled/produced not to mention injury to operators. Failure to observe the indications will also nullify the warranty.

 **CAUTION - DANGER**  
ALL OPERATIONS TO PUT OUT A FIRE MUST BE CARRIED OUT BY PERSONNEL WHO ARE ADEQUATELY INFORMED AND TRAINED CONCERNING THE RISKS AND HAZARDS THAT MAY ARISE DURING EXECUTION OF SAID ACTIVITIES. THEY MUST HAVE READ AND UNDERSTOOD THE SAFETY PRESCRIPTIONS PROVIDED IN THIS INSTRUCTION MANUAL AND BE IN GOOD PSYCHO-PHYSICAL SHAPE.

In the event of a fire affecting parts of the machine, or the processed product, always use a type "C" C<sub>02</sub> extinguisher.

A fire extinguisher of this type must be kept next to the machine work station at all times.

## 9. SCRAPPING AND DISPOSAL

 **DANGER - WARNING**  
IF YOU DECIDE NOT YOU NO LONGER WISH TO USE THE MACHINE DESCRIBED IN THIS MANUAL BECAUSE IT HAS BECOME OBSOLETE AND/OR IRREPARABLY DAMAGED OR WORN TO A POINT WHERE ANY FORM OF REPAIR WOULD NOT BE AN ECONOMICALLY VIABLE SOLUTION, IT MUST BE PUT OUT OF SERVICE AND RENDERED INOPERATIVE AND FREE FROM ALL POTENTIAL HAZARDS.

Decommissioning of the machine must be carried out by specialised and suitably equipped personnel. If the client does not have the right personnel or tools to be able to proceed with demolition of the machine in total safety and in such a way as to safeguard the operators involved, he must seek the assistance of the machine manufacturer's technical staff.

Before starting the scrapping procedures display signs informing persons in the area that work is in progress.

### 9.1. SCRAPPING

 **NOTES**  
*To be able to perform the necessary tasks in maximum safety, the areas around the machine, for a whole 360° and over a distance of at least 2000 mm, must be free of walls, other machinery, equipment or other elements, such as support pillars, which might get in the way.*

The main sequential stages for dismantling and scrapping include the following (the list is provided as a guideline and is not exhaustive): disassemble all machine components and consign them to an authority or company for differentiated collection in compliance with the relative legislation in force.

All operations to disconnect the machine must be carried out using suitable equipment and tools of an appropriate size (e.g. a flathead or Phillips screwdriver, hex wrenches, Allen keys, etc.), depending on the type of fasteners.

During dismantling procedures do not enter the interior of the machine or climb under or on top of it for any reason: always work while standing alongside the machine.

Before disassembling parts and/or disconnecting and/or loosening any joining elements, take steps to ensure that the connected parts cannot subsequently fall on top of yourself or other exposed persons.

This must be achieved also using ancillary supports or restraints, or approved and certified lifting devices in compliance with statutory legislation in force in your country.

Never carry out dismantling procedures single-handedly. Always make sure there is someone there to provide assistance and/or help in the event of accidents. Said assistant must have the professional training of a maintenance technician or higher.

Pay attention to any decals affixed to the components to be disconnected and next to terminal boxes.

When the machine has been fully dismantled all the identification plates of the machine and all documents referring to the machine must be destroyed.

## 9.2. DISPOSAL



### DANGER - WARNING

**DISPOSE OF THE MACHINE COMPONENTS IN ACCORDANCE WITH OPERATING METHODS WHICH OBSERVE THE MAIN REGULATIONS GOVERNING SAFETY AND ENVIRONMENTAL PROTECTION IN THE COUNTRY OF DISPOSAL.**

The machine can be disposed of without having to reduce it to small pieces; simply separate the main units it is made up of and load them onto a lorry for transfer to a scrap merchant.

Clearly, this operation must be performed using adequate lifting and handling equipment including forklifts, hoists, A-frames, overhead travelling cranes, etc., all of which must be approved and certified in compliance with statutory legislation and applicable regulations.

Proceed with disposal operations in accordance with the relative legislation in force by contacting the relative bodies and/or specialized waste disposal companies authorized to handle industrial machinery and/or waste disposal to make sure that all plastics, metal materials and electrical components which must be disposed of separately are duly sorted.

The employer must be aware of all the statutory legislation in force in the country of disposal and must operate in compliance with the relative provisions.

It is prohibited to dump the machine in environment. All violations are punishable by law.

## IDENTIFICATION DATA

### MANUFACTURER

ALFAMACCHINE S.r.l.

Address

Via Selva, 23/25 - 47122 FORLI

Tel. +39 0543 783301 Fax +39 0543 783302

E-mail: customerservice@alfamacchine.com

Name	<b>FRAME ASSEMBLING MACHINE</b>
Function	<b>ASSEMBLY OF FRAMES BY INSERTION OF METAL V-NAILS</b>
Model / Type	U300 (previous version MINIGRAF 3)
Serial number	
Year of construction	
Manual Revision	<b>01</b>

## DOCUMENT

### INSTRUCTION MANUAL

No. of volumes: 1

Date: 09/02/2016

Revision: 01

© Copyright 2011 - ALFAMACCHINE S.r.l.

Unless expressly authorized in writing by ALFAMACCHINE S.r.l., this manual nor any part of it, may be copied in any form, modified, transcribed, translated into any language, made available to third parties or in any way used in a manner which could have a negative impact on the interests of ALFAMACCHINE S.r.l..

**All violations of the foregoing prescriptions are subject to penalties in compliance with the law and the rules of copyright.**

**TABLE 0 - EXPLODED VIEW OF THE MACHINE**

Numero oggetto	Numero documento	Commenti	Quantita
2*		HORIZONTAL CLAMP CYLINDER CILINDRO BLOCCAGGIO ORIZZONTALE - 225120011	1
4*		HORIZONTAL CLAMP SUPPORT SUPPORTO BLOCCAGGIO ORIZZONTALE - 382002020	2
23		KNOB D.30 POMELLO D.30 - 753320001	1
25		MAGAZINE P.V. VALVE VALVOLA P.V. MAGAZZINO - 732140001	1
29		M3 TOP BENCH PIANO M3 - 391250391	1
30		M3 METAL FRAME CARCASSA M3 - 291690010	1
31*		VERTICAL CLAMP CYLINDER CILINDRO BLOCCAGGIO VERTICALE - 225220010	2
32*	TAB 23	VERTICAL CLAMP GROUP ASSEMBLY GRUPPO BLOCCAGGIO VERTICALE M3	1
33*	TAB 22A	AFC BRAKE ASSEMBLY MONTAGGIO GRUPPO FRENO AFC	1
34*	TAB 21	M3 FENCES GROUP ASSEMBLY MONTAGGIO GRUPPO SQUADRA M3	1
35*	TAB 20	HEAD GROUP ASSEMBLY MONTAGGIO GRUPPO TESTA	1
36*	TAB 24	CE SAFETY GUARD PROTECTION COMPLETE PROTEZIONE CE COMPLETA - 248990202	1
37	TAB 22B	FRONTAL CLAMP ASTIA FOGLIA BLOCCAGGIO ORIZZONTALE - 242170010	1
38		AIR PRESSURE GAUGE MANOMETRO - 258310220	1
39		AIR PRESSURE REGULATOR REGOLATORE DI PRESSIONE - 736330002	1
41		AIR FITTING 4MM SIZE RACCORDO PER TUBO 4MM - 730090033	3
69		MAIN AIR PRESSURE CONNECTION RACCORDO INGRESSO ARIA COMPRESSA - 730510001	1

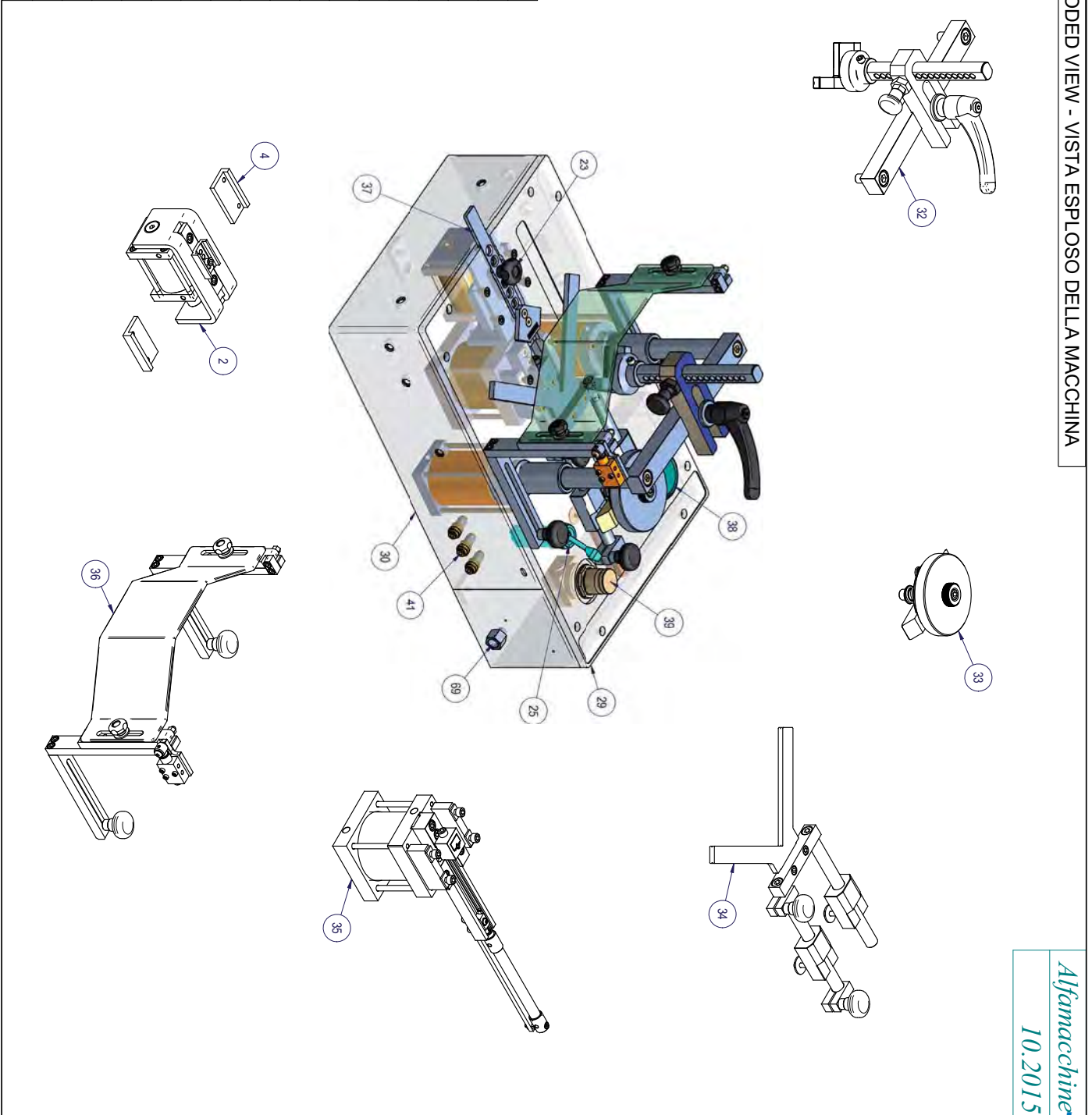

U300 TAB.0 MACHINE ASSEMBLY EXPLODED VIEW - VISTA ESPLOSO DELLA MACCHINA

Alfamacchine  
10.2015

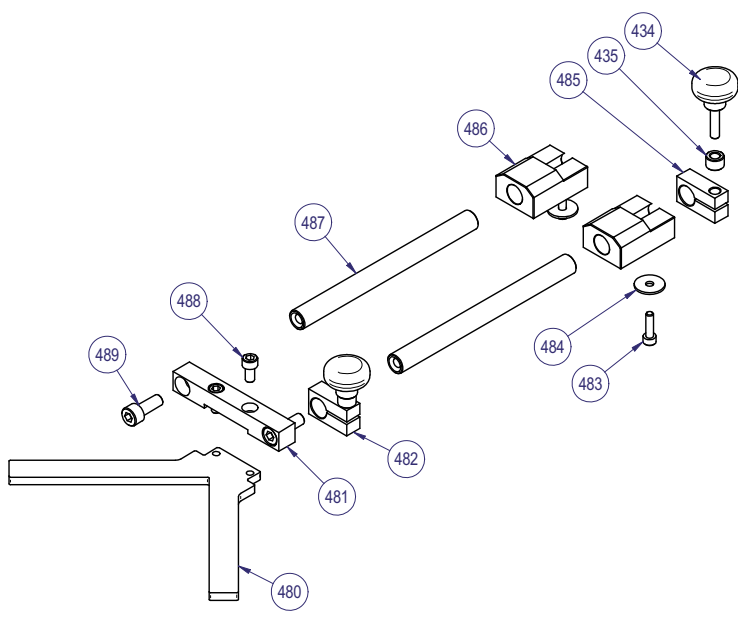
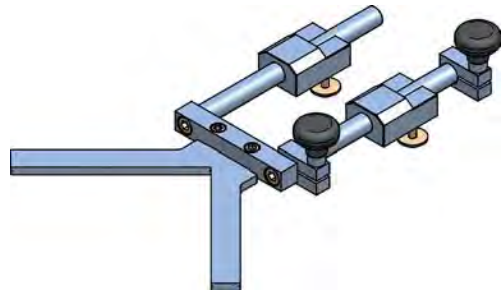

**TABLE 20 - HEAD UNIT INSTALLATION**

*Alfamacchine*  
**10.2015**

Numero oggetto	Oggetto	Titolo	Quantità
234	718100002	RONDELLA PIANA M5 UNI 6592 5x10 Z.B.	2
235	710100042	VITE TCEI M5x10 UNI 5931 8.8 Z.B.	2
237	710100078	VITE TCEI M6x22 UNI 5931 8.8 Z.B.	2
238	383600020	SUPPORTO BLOCCAGGIO CARICATORE	2
245	384200050	SUPPORTO A L	1
263	753420008	BOCCOLA ALVEOLATA Di16 De18 L20	1
264	722320001	GUARNIZIONE A LABBRO DI 062	1
267	720250005	OR 6237 Di59.69 CORDA 5.34 NBR70	1
268	720250004	OR DI. 64,77 CORDA 2,62	1
269	710100105	VITE TCEI M6x25 UNI 5931 8.8 Z.B.	2
272	722260014	GUARNIZIONE A LABBRO M5 7060	1
290	710100070	VITE TCEI M6x8 UNI 5931 12.9	5
291	394950030	TESTINA H10	1
292	394950050	TESTINA H15	1
293	394950040	TESTINA H12	1
294	394950020	TESTINA H7	1
295	394950060	TESTINA H5	1
300	710100066	VITE TCEI M6x80 UNI 5931 8.8 Z.B.	4
301	352200050	COPPA D70 CIL. ESP. M3 M4	1
302	298420040	MARTELLETTO M3-M4-M44 - COMPLETO	1
303	244240130	TESTATA U300 - COMPLETA	1
304	381300080	DISTANZIALE PER GRUPPO DI SPARO M3	2
305	381600100	SPESSORE IN GOMMA	4
306	710100082	VITE TCEI M6x40 UNI 5931 8.8 Z.B.	4
307	398350031	MAGAZZINO	1
308	221330010	SPINGIPUNTI COMPLETO M3	1

**TABLE 21 - FENCE UNIT INSTALLATION**

U300	TAB.21	FENCE GROUP ASSEMBLY - MONTAGGIO GRUPPO SQUADRA	 10.2015
			
Numero oggetto	Oggetto	Titolo	Quantità
434	753320004	POMELLO MASCHIO M6x25	1
435	336100020	RONDELLA MORSETTO	1
480	375200010	SQUADRA 90°	1
481	383900020	SUPPORTO GUIDA ASTE	1
482	243150010	MORSETTO FINECORSA SQUADRA MOBILE	2
483	710100046	VITE TCEI M5x18 UNI 5931 8.8 Z.B.	4
484	718250005	RONDELLA PIANA 5x20 UNI 6593 Z.B.	4
485	393150010	MORSETTO BLOCCAGGIO ASTE SQUADRA M3-A2M	1
486	383900010	SUPPORTO GUIDA ASTA	2
487	334000020	ASTA SQUADRE	2
488	710100073	VITE TCEI M6x12 UNI 5931 8.8 Z.B.	2
489	710100139	VITE TCEI M8x20 UNI 5931 8.8 Z.B.	2

**TABLE 22A - AFC BRAKE**

U300	TAB.22A	AFC BRAKE SYSTEM - FRENO AFC	<p><i>Alfamacchine</i></p> <p>10.2015</p>
------	---------	------------------------------	---



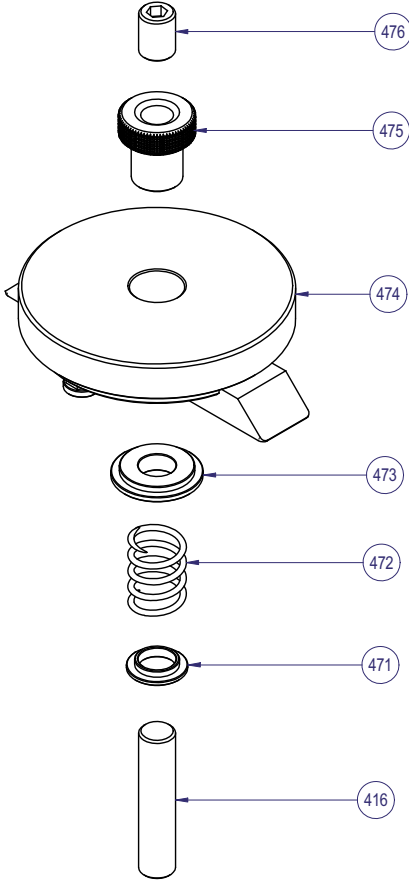

Numero oggetto	Oggetto	Titolo	Quantità
416	336210120	GRANO TRAVERSA M12	1
471	336100050	RONDELLA PER MOLLA FRENO M3 PICCOLA	1
472	765000004	MOLLA D2 DI15 L35	1
473	336100040	RONDELLA PER FRENO M3 GRANDE	1
474	225170010	COMPLESSIVO FRENO M3	1
475	336300010	POMELLO FRENO M3	1
476	714300042	GRANO STEI 12x16 UNI 5923 12.9 PASSO 1.25	1

**TABLE 22B - ROD CLAMP**

U300	TAB.22B	FRONTAL CLAMP - ASTA A FOGLIA
------	---------	-------------------------------

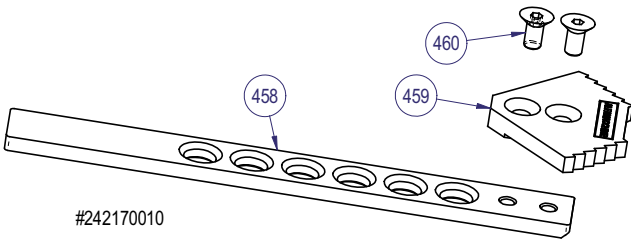

#242170010

Numero oggetto	Oggetto	Titolo	Quantità
458	384800010	PIATTO ASTA FOGLIA M3	1
459	391950010	CORPO FOGLIA M3-M4	1
460	710200041	VITE TSPEI 5x10 UNI 5933 10.9 Z.B.	2

**TABLE 23 - VERTICAL CLAMP UNIT**

U series	TAB.23	VERTICAL CLAMP GROUP - GRUPPO BLOCC. VERTICALE	 <span style="font-size: 1.2em; color: green;">10.2015</span>
----------	--------	--	--

Numero oggetto	Oggetto	Titolo	Quantità
401	753320010	POMELLO CON SPINTORE A MOLLA	1
402	334000100	ASTA BLOCC. VERTICALE PORTA TAMPONE	1
404	397100001	PAD L-SHAPED 90 SHORE - BLACK	1
405	397100002	PAD L-SHAPED 75 SHORE - YELLOW	1
406	397100003	PAD L-SHAPED 65 SHORE - BLUE	1
408	710100151	VITE TCEI M10x25 UNI 5931 8.8 Z.B.	2
412	397100005	SUPPORTO ANGOLO INSERTO VULKOLLAN	1
413	244120130	PORTA TAMPONE	1
414	383600070	SUPPORTO CORTO ASTA BLOCCAGGIO VERTICALE	1
415	376400010	TRAVERSA	1
416	336210120	GRANO TRAVERSA M12	1
417	336100030	RONDELLA BLOCCAGGIO SUPPORTO BL.V.	1
418	244660010	MANIGLIA PER TRAVERSA M12	1

**TABLE 24 - EC SAFEGUARD**

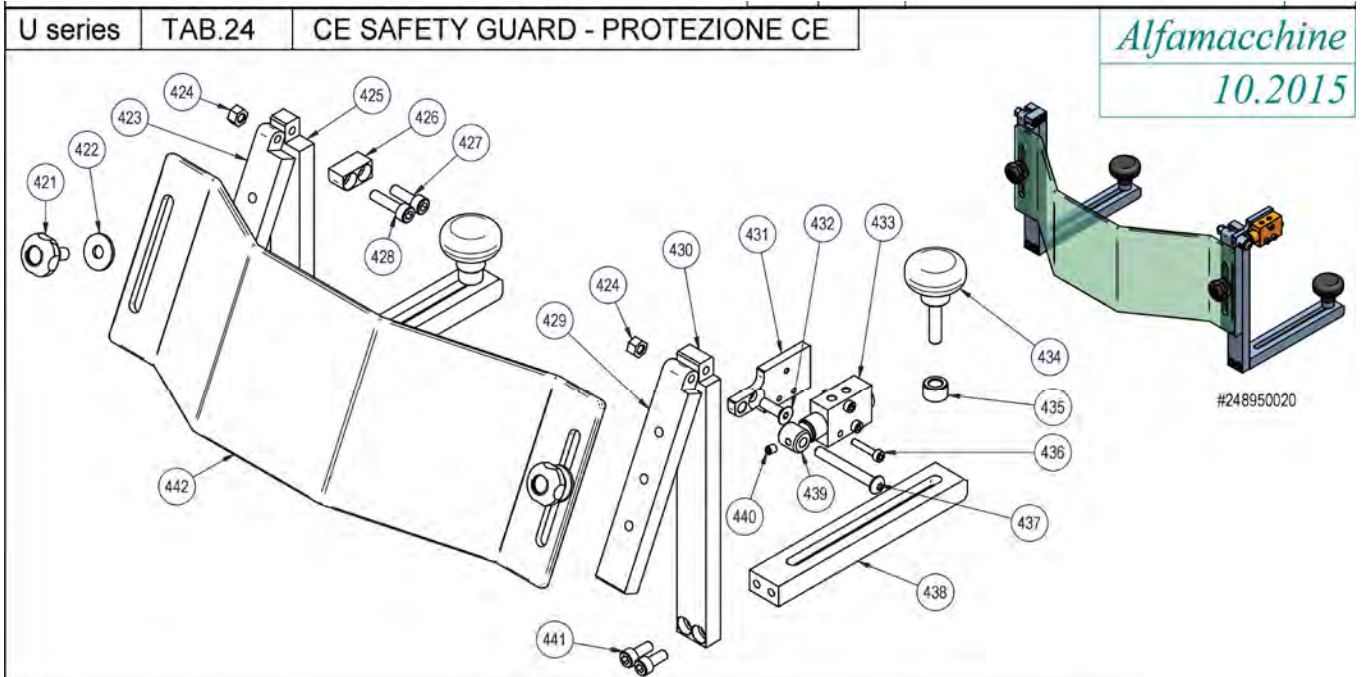

Numero oggetto	Oggetto	Titolo	Quantità	Numero oggetto	Oggetto	Titolo	Quantità
421	753320009	VOLANTINO D20 M6x10 ZN	2	432	710200055	VITE TSPEI 5x16 UNI 5933 10.9 ZB	1
422	718100015	RONDELLA PIANA M6 UNI 6593 6x18 Z.B.	2	433	732540003	MICROVALVOLA 0ALF-106 A	1
423	381300190	SUPPORTO SX PROTEZIONE CE	1	434	753320004	POMELLO MASCHIO M6x25	2
424	715650002	DADO M5 Medio UNI 5588 6S P.G.Z.B.	2	435	336100020	RONDELLA MORSETTO	2
425	381300200	SUPPORTO FISSO SX PROTEZIONE CE	1	436	710100203	VITE TCEI M3x16 UNI 5931 ZB	3
426	388200030	BLOCCO STAFFA PROTEZIONE CE	1	437	710240013	VITE TBEI M5x40 ZB	1
427	710100045	VITE TCEI M5x16 UNI 5931 8.8 Z.B.	1	438	388200070	SUPPORTO SCORREVOLE PROTEZIONE CE	2
428	710100047	VITE TCEI M5x20 UNI 5931 8.8 Z.B.	1	439	394650020	CAMMA PROTEZIONE	1
429	381300180	SUPPORTO DX PROTEZIONE CE	1	440	714300005	GRANO STEI 4x5 UNI 5927 14.9 A PUNTA	1
430	381300170	SUPPORTO FISSO DX PROTEZIONE CE	1	441	710100043	VITE TCEI M5x12 UNI 5931 8.8 Z.B.	4
431	388200020	SUPPORTO VALVOLA PROTEZIONE	1	442	398950020	PROTEZIONE CE M3	1



**A Fletcher Company**

**ALFAMACCHINE S.r.l.**

Via Selva, 23/25 - 47122 Forlì - FC -  
Tel. +39-0543/783301 Fax +39-0543/783302  
<http://www.alfamacchine.com>